



**FORD**

**OPERATOR'S MANUAL**

**1710**



## PLEASE READ CAREFULLY:

For a complete list of the pre-delivery service checks performed by your dealer, refer to PRE-DELIVERY SERVICE on the upper portion of page 61 and 63. The copy on page 61 is your record of the service performed, and the copy on page 63, which is to be removed from the manual, is your dealer's. MAKE SURE THAT YOU AND THE DEALER SIGN BOTH COPIES.

After you have operated your tractor for fifty hours, take this manual and your tractor to your dealer. He will then perform the factory recommended 50-HOUR SERVICE as listed on the lower portions of pages 61 and 63 – without charge – except for lubricant, oil, or filters replaced as part of normal maintenance. MAKE SURE THAT YOU AND THE DEALER SIGN BOTH COPIES.

A PRODUCT IDENTIFICATION PLATE is located on the left-hand side of the transmission housing. The numbers on the plate are important should your tractor require future service. For your convenience, have your dealer record the numbers in the appropriate spaces below.

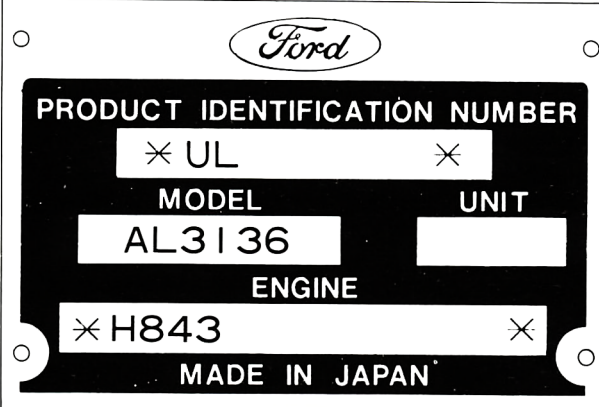

The image shows a Ford Product Identification Plate. At the top center is the Ford logo. Below it, the text "PRODUCT IDENTIFICATION NUMBER" is printed. Underneath, there are two fields: "MODEL" and "UNIT". The "MODEL" field contains "AL3136" and the "UNIT" field is empty. Below these fields is the "ENGINE" field, which contains "H843". At the bottom of the plate, it says "MADE IN JAPAN".

PRODUCT IDENTIFICATION NUMBER	
× UL ×	
MODEL	UNIT
AL3136	
ENGINE	
× H843 ×	
MADE IN JAPAN	

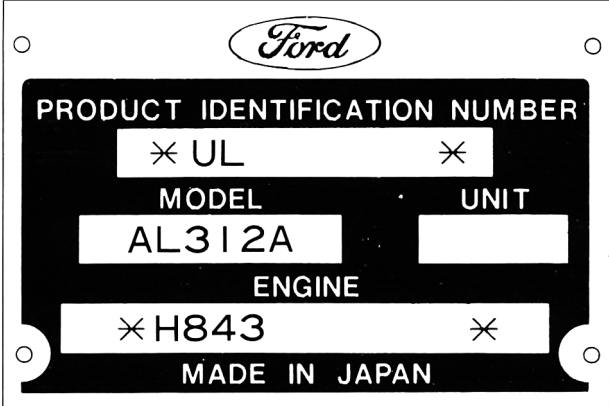

The image shows a second Ford Product Identification Plate, identical in layout to the first. The "MODEL" field contains "AL312A" and the "UNIT" field is empty. The "ENGINE" field contains "H843". At the bottom, it says "MADE IN JAPAN".

PRODUCT IDENTIFICATION NUMBER	
× UL ×	
MODEL	UNIT
AL312A	
ENGINE	
× H843 ×	
MADE IN JAPAN	

Ford policy is one of continuous improvement, and the right to change prices, specification or equipment at any time without notice is reserved.







































All data given in this book is subject to production variations. Dimensions and weights are approximate only and the illustrations do not necessarily show tractors in standard condition. For exact information about any particular tractor please consult your Ford tractor dealer.

# CONTENTS

INTERNATIONAL SYMBOLS .....	3
SAFETY PRECAUTIONS .....	4–5
CONTROLS AND INSTRUMENTS .....	6–13
SEAT, LIGHT AND ENGINE CONTROLS .....	6
LIGHTING .....	7
INSTRUMENT PANEL .....	7–8
THROTTLE CONTROLS .....	8–9
BRAKE CONTROLS .....	9–10
DIFFERENTIAL CONTROL .....	10
TRANSMISSION AND PTO CONTROLS .....	10–12
HYDRAULIC LIFT SYSTEM CONTROLS .....	12–13
OPERATION .....	14–27
BREAK-IN PROCEDURES .....	14
STARTING THE ENGINE .....	14–15
STOPPING THE ENGINE .....	15
OPERATING THE TRANSMISSION, FOUR-WHEEL DRIVE AND PTO .....	15–18
TOWING THE TRACTOR .....	18
OPERATING THE DIFFERENTIAL LOCK .....	18
OPERATING THE HYDRAULIC LIFT SYSTEM .....	19–21
DRIVING THE TRACTOR .....	22
WHEEL TREAD SETTINGS .....	22–23
TRACTOR WEIGHTING .....	24–25
TIRE PRESSURES .....	25–27
LUBRICATION AND MAINTENANCE .....	28–51
LUBRICATION AND MAINTENANCE CHART .....	28–29
TWO-WHEEL DRIVE .....	28
FOUR-WHEEL DRIVE .....	29
FUEL AND LUBRICANTS .....	30–33
FUEL AND LUBRICANT SERVICE PROCEDURES .....	33–38
GENERAL MAINTENANCE .....	38–48
TRACTOR STORAGE .....	49–50
GENERAL TORQUE SPECIFICATION TABLE .....	51
SPECIFICATIONS .....	52–55
SAFETY AND INSTRUCTION DECALS .....	56–59
PREDELIVERY AND 50-HOUR SERVICE .....	61–63

# INTERNATIONAL SYMBOLS

As a guide to the operation of your tractor, various international symbols have been utilized on the instruments and controls. The symbols are shown below with an indication of their meaning.

	Engine speed		Lights		Battery
	Hours recorded		Horn		Power take-off (on)
	Engine water temperature		Power take-off (off)		
	Air filter		Increase		"Tortoise," slow or minimum setting
	Pressurized open slowly		Decrease		"Hare," fast or maximum setting
	Engine oil pressure		Warning		
	Hazard warning		Control lever operating direction		
	Axle connect		Rock shaft (raised)		
	Axle disconnect		Rock shaft (lowered)		
	Continuously variable		Remote cylinder (extended)		
	Diesel fuel		Remote cylinder (retracted)		
	Fuel cut-off		Remote cylinder (float)		
	Fuel level		Differential lock		
	Transmission oil pressure		Read operators manual		
	Creep range		Neutral		
	High range		Forward		
	Low range		Reverse		
	Warning! Contains asbestos				

# SAFETY PRECAUTIONS

The following precautions are suggested to help prevent accidents.

A careful operator is the best operator. Most accidents can be avoided by observing certain precautions. Read and take the following precautions before operating this tractor to help prevent accidents. Equipment should be operated only by those who are responsible and instructed to do so.

## THE TRACTOR

1. Read the Operator's Manual carefully before using the tractor. Lack of operating knowledge can lead to accidents.
2. Use an approved Rollbar and Seat Belt for safe operation. Overturning a tractor without a rollbar can result in death or injury. If your tractor is not equipped with a rollbar and seat belt, see your Ford Tractor Equipment Dealer.
3. Always use the seat belt. Do not use the seat belt if the rollbar has been removed from the tractor.
4. If a front end loader is to be installed, always use a ROPS canopy to avoid injury from falling objects.
5. Use the handholds and step plates when getting on and off the tractor to prevent falls. Keep steps and platform cleared of mud and debris.
6. Do not permit anyone but the operator to ride on the tractor. There is no safe place for extra riders.
7. Replace all missing, illegible, or damaged safety decals. See list of decals on page 56.
8. Keep safety decals clean of dirt and grime.

## SERVICING THE TRACTOR

1. The cooling system operates under pressure which is controlled by the radiator cap. It is dangerous to remove the cap while system is hot. Always turn cap slowly to the first stop and allow the pressure to escape before removing the cap entirely.
2. Do not smoke while refueling the tractor. Keep any type of open flame away. Wait for engine to cool before refueling.
3. Keep the tractor in good operating condition for your safety. An improperly maintained tractor can be hazardous.
4. Keep open flame away from battery or cold weather starting aids to prevent fires or explosions. Use jumper cables according to instructions to prevent sparks which could cause explosion.
5. Stop the engine before performing any service on the tractor.
6. Escaping hydraulic/diesel fluid under pressure can penetrate the skin causing serious injury.
  - **DO NOT** use your hand to check for leaks. Use a piece of cardboard or paper to search for leaks.
  - Stop engine and relieve pressure before connecting or disconnecting lines.
  - Tighten all connections before starting engine or pressurizing lines.

If fluid is injected into the skin obtain medical attention immediately or gangrene may result.

7. Do not modify or alter or permit anyone else to modify or alter this tractor or any of its components or any tractor function without first consulting a Ford Tractor-Equipment Dealer.
8. The fuel oil in the injection system is under high pressure and can penetrate the skin. Unqualified persons should not remove or attempt to adjust a pump, injector, nozzle or any other part of the fuel injection system. Failure to follow these instructions can result in serious injury.
9. Continuous long term contact with used engine oil may cause skin cancer. Avoid prolonged contact with used engine oil. Wash skin promptly with soap and water.
10. Some components on your tractor, such as gaskets and friction surfaces (brake linings, clutch linings, etc.), may contain asbestos. Breathing asbestos dust is dangerous to your health. You are therefore advised to have any maintenance or repair operations on such components carried out by an authorized Ford tractor dealer. If, however, service operations are to be undertaken on parts that contain asbestos, the essential precautions listed below must be observed:
  - Work out of doors or in a well ventilated area.
  - Dust found on the tractor or produced during work on the tractor should be removed by extraction not by blowing.
  - Dust waste should be dampened, placed in a sealed container and marked to ensure safe disposal.
  - If any cutting, drilling, etc., is attempted on materials containing asbestos, the item should be dampened and only hand tools or low speed power tools used.
11. Continuous long term contact with used engine oil has caused skin cancer in animal tests. Avoid prolonged skin contact with used engine oil. Wash skin promptly with soap and water.

## OPERATING THE TRACTOR

1. Apply the parking brake, place the P.T.O. lever in the "OFF" position, the lift control lever in the down position, the remote control valve levers in the neutral position, and the transmission in neutral before starting the tractor.
2. Do not start the engine or operate controls while standing beside the tractor. Always sit in the tractor seat when starting the engine or operating controls.
3. Do not bypass the neutral start switch. Consult your Ford Tractor-Equipment Dealer if your neutral start controls malfunction. Use jumper cables only in the recommended manner. Improper use can result in tractor runaway.
4. Avoid accidental contact with the gear shift lever while the engine is running. Unexpected tractor movement can result from such contact.
5. Do not get off the tractor while it is in motion.
6. Disengage PTO, shut off the engine and apply the parking brake before getting off the tractor.
7. Do not park the tractor on a steep incline.

(cont.)

# SAFETY PRECAUTIONS (Continued)

8. Do not operate the tractor engine in an enclosed building without adequate ventilation. Exhaust fumes can cause death.
9. If power steering or engine ceases operating, stop the tractor immediately.
10. Pull only from the swinging drawbar or the lower link drawbar in the down position. Use only a drawbar pin that locks in place. Pulling from the tractor rear axle or any point above the axle may cause the tractor to upset.
11. If the front end of the tractor tends to rise when heavy implements are attached to the three-point hitch, install front end or front wheel weights. Do not operate the tractor with a light front end.
12. Always set the hydraulic selector lever in position control when attaching equipment and when transporting equipment. Be sure hydraulic couplers are properly mounted and will disconnect safely in case of accidental detachment of implement.
13. Do not leave equipment in the raised position.
14. Use the Flasher/Turn Signal Lights and SMV signs when traveling on public roads both day and night unless prohibited by law.
15. Be sure tractor lights are adjusted to prevent blinding an oncoming vehicle operator.

## DRIVING THE TRACTOR

1. Watch where you are going especially at row ends, on roads, around trees and low hanging obstacles.
2. To avoid upsets drive the tractor with care and at speeds compatible with safety, especially when operating over rough ground, when crossing ditches or slopes, and when turning corners.
3. Lock tractor brake pedals when transporting on roads to provide two wheel braking.
4. Keep the tractor in the same gear when going downhill as used when going uphill. Do not coast or free wheel down hills.
5. Any towed vehicle whose total weight exceeds that of the towing tractor must be equipped with brakes for safe operation.
6. When the tractor is stuck or tires are frozen to the ground, back up the tractor to prevent upset.
7. Always check overhead clearance, especially when transporting the tractor.
8. When operating at night, adjust lights to prevent blinding an oncoming driver.

## OPERATING THE P.T.O.

1. When operating P.T.O. driven equipment, shut off the engine and wait until the P.T.O. stops before getting off the tractor and disconnecting the equipment.
2. Do not wear loose clothing when operating the power take-off, or when near rotating equipment.
3. When operating stationary P.T.O. driven equipment, always place both gear shift lever in neutral apply the tractor parking brake and block the rear wheels front and back.
4. To avoid injury, do not clean, adjust, unclog or service P.T.O. driven equipment when the tractor engine is running.
5. Make sure the P.T.O. master shield is installed at all times and always replace the P.T.O. shield cap when the P.T.O. is not in use.

## DIESEL FUEL

1. Under no circumstances should gasoline, alcohol or blended fuels be added to diesel fuel. These combination can create an increased fire or explosive hazard. Such blends are more explosive than pure gasoline in a closed container such as a fuel tank. **Do not use these blends.**
2. Never remove the fuel cap or refuel with the engine running or hot.
3. Do not smoke while refueling or when standing near fuel.
4. Maintain control of the fuel filler pipe nozzle when filling the tank.
5. Do not fill the fuel tank to capacity. Allow room for expansion.
6. Wipe up spilled fuel immediately.
7. Always tighten the fuel tank cap securely.
8. If the original fuel tank cap is lost, replace it with a Ford approved cap. A non-approved, proprietary cap may not be safe.
9. Keep equipment clean and properly maintained.
10. Do not drive equipment near open fires.
11. Never use fuel for cleaning purposes.
12. Arrange fuel purchases so that winter grade fuels are not held over and used in the spring.

When you see this symbol



it means:

**ATTENTION BECOME ALERT! YOUR SAFETY IS INVOLVED!**

# CONTROLS AND INSTRUMENTS

## SEAT, LIGHT, AND ENGINE CONTROLS

### TRACTOR SEAT

Your Ford 1710 Tractor is equipped with a suspension seat as shown in Figure 1. The seat is adjustable to obtain the most comfortable position.

To move the seat fore and aft, move the seat release lever to the forward and slide the seat fore or aft as desired, Figure 2.

To adjust the seat for flotation, turn the flotation adjustment bolt right for a firm ride, or left for a soft ride, Figure 2.

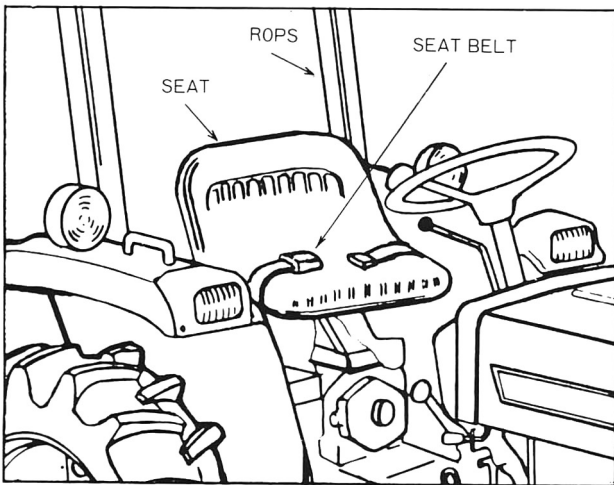

Figure 1 – Tractor Seat, ROPS and Seat, Belt

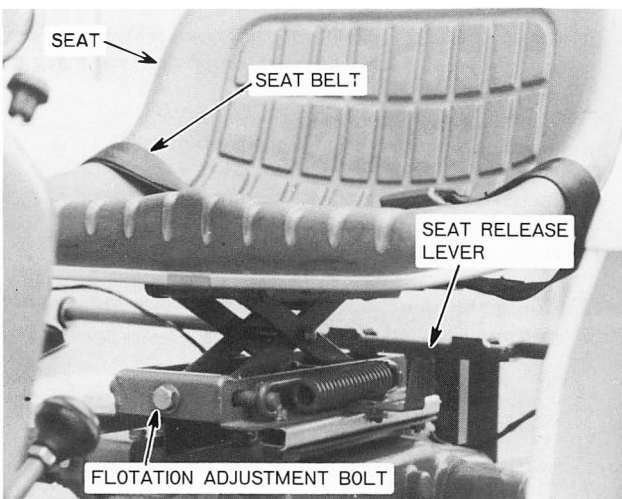

Figure 2 – Tractor Seat Adjustment

### ROLLOVER PROTECTIVE STRUCTURE (ROPS)

A Roll Over Protective Structure (ROPS) and seat belts were standard equipment for this

tractor at time of factory assembly. If the ROPS was deleted by the original purchaser or has been removed, it is recommended that you equip your tractor with a Roll Over Protective Structure (ROPS) and seat belts. ROPS are effective in reducing injuries during tractor overturn accidents. Overturning tractor without a ROPS can result in serious injury or death.

Roll Over Protective Structure (ROPS), and seat belts are available from your Ford Tractor Equipment Dealer.

The safety offered by the roll bar and seat belt is minimized if your seat belt is not buckled. Always use your seat belt – they save lives.



**WARNING:** Always wear the seat belt when the tractor is equipped with a ROPS. DO NOT use the seat belt if the ROPS is removed from the tractor.



**WARNING:** DO NOT attach chains or ropes to the roll bar for pulling purposes since the tractor can tip backward. Always pull from the tractor drawbar. Be careful when driving through door openings or under low overhead objects. Make sure there is sufficient overhead clearance for the roll bar.

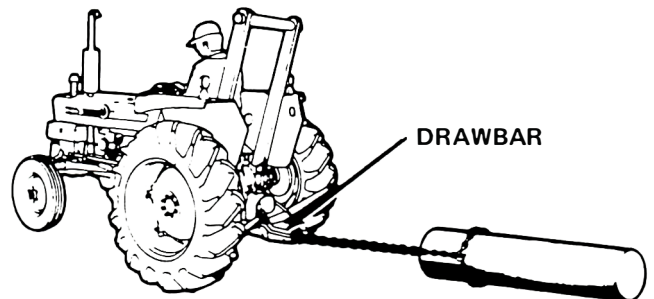

### ADJUSTING THE SEAT BELT

To lengthen the belt, tip the buckle end down and pull on the buckle until the ends can be joined.

To shorten the belt, buckle it, then pull on the loose end until the belt is snug.

If the seat belt is to be cleaned, use soap and water. Do not use carbon tetrachloride, naphtha, etc., as these will weaken the webbing. For the same reason, do not bleach or redye the webbing. Replace seat belt if worn or damaged.

## LIGHTING

### FLASHER WARNING LAMP

Your Ford tractor is equipped with flasher warning lamps, Figure 3. The switch for the warning lamps is located on the right side of the instrument panel.

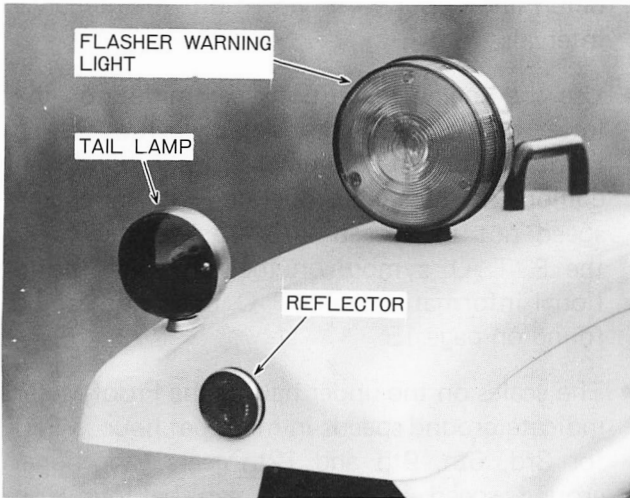

Figure 3 – Flasher Warning and Tail Lamp

The light switch must be in one of the “ON” positions before the flasher will operate.

For your protection, use the flasher warning lamp and the SMV emblem when traveling on public roads, day or night.

### LIGHT SWITCH

The light switch, shown in Figure 4, is a push-pull type switch. Its positions are:

- Full in . . . . . Off
- Intermediate . . . . . Headlights (High Beam),  
and Tail Lamp
- Full out . . . . . Headlights (Low Beam),  
and Tail Lamp

## INSTRUMENT PANEL

### KEY SWITCH

The key switch is shown in Figure 4. Turning the key to the left will activate the cold-start aid. Turning the key to the right to the “on” position will activate the warning lights and instruments. Turning the key further right to the “start” position will start the engine. Upon release, the key will spring return to the “on” position.

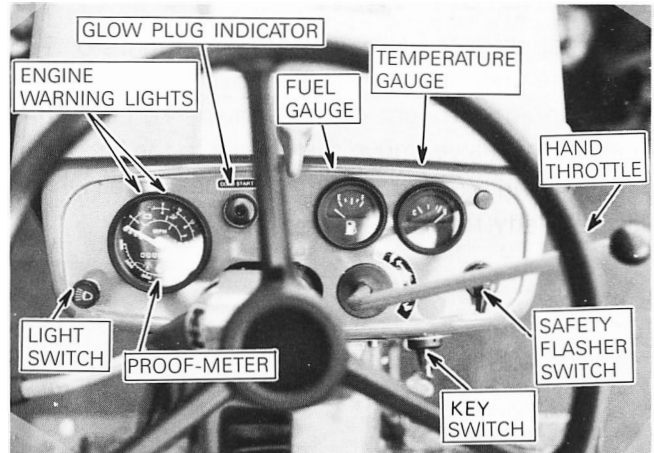

Figure 4 – Instrument Panel

The starting circuit can only be activated when the main shift lever is in neutral. Always check to make certain the transmission main shift lever and P. T. O. lever are in neutral before attempting to start the engine. Refer to page 13 for complete starting instructions.

**IMPORTANT:** The key switch must remain in the ON position while operating the engine. The warning lights and battery charging system will not function with the switch in the OFF position.

### FUEL GAUGE

The fuel gauge is shown in Figure 4 and 5. The needle indicates the amount of fuel in the tank.

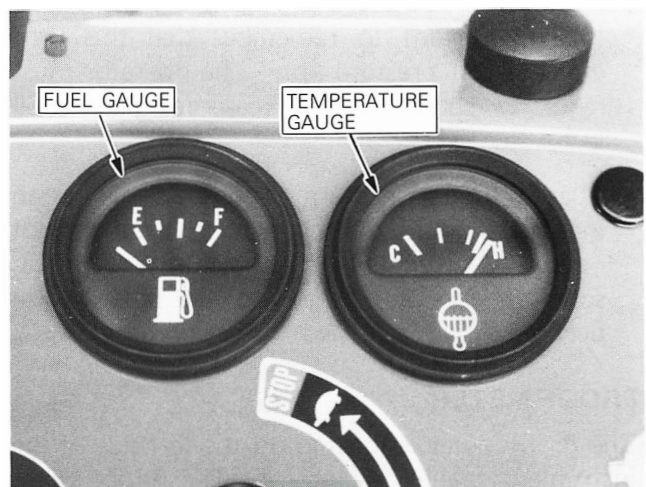

Figure 5 – Temperature Gauge and Fuel Gauge

# CONTROLS AND INSTRUMENTS

---

## FUEL SHUTOFF VALVE

The fuel shutoff valve is shown in Figure 6. To open the fuel shutoff valve, move the handle so that it points straight up and down. To close the fuel shutoff valve, move the handle to the horizontal position. Always shut off the valve when servicing any portion of the fuel system.

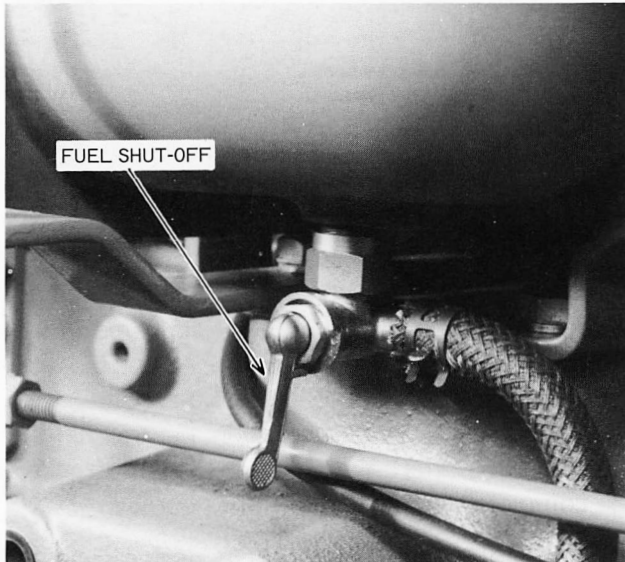

Figure 6 – Fuel Shutoff Valve

## WARNING LIGHTS

The engine oil pressure and charge indicator warning lights are located as shown in Figure 4. When the key switch is turned “on” these lights will come on. After the engine has been started, the lights should go out within a few seconds. If they do not go out:

- Engine oil pressure warning light: Stop the engine immediately and investigate the cause. It is important to remember that this light indicates oil pressure only. The operator must regularly check the crankcase for proper oil level.
- Charge indicator warning light: This is an indication that the charging system is not operating normally. Investigate the cause as soon as possible, otherwise the battery will become fully discharged.

## PROOF-METER

The Proof-Meter is located on the left side of the instrument panel, Figure 4. The Proof-Meter indicates:

- The hours and portions of hours your tractor has operated, based on an average engine speed of 2170 rpm. Engine speeds below 2170 rpm accumulate engine hours at a slower rate than clock hours. Engine speeds above 2170 rpm accumulate engine hours faster than clock hours. Use the Proof-Meter as a guide to determine hourly service and maintenance intervals.
- Use the engine revolutions per minute on the lower half of the Proof-Meter when operating P. T. O. driven equipment. P. T. O.-driven equipment must be operated at an engine speed not to exceed 2422 rpm as shown by the P. T. O. symbol on the rpm scale. Additional information on P. T. O. operation can be found on page 15.
- The scales on the upper half of the Proof-Meter indicate ground speeds in miles per hour (MPH) for 3rd, 6th, 9th and 12th gears. Additional ground speed information can be found on page 50.

## TEMPERATURE GAUGE

The engine coolant temperature gauge is shown in Figure 4. When the needle is in the middle area, the engine is at its normal operating temperature. The needle at the “H” end indicates an overheated engine.



**WARNING:** When engine is at operating temperature always relieve pressure in the cooling system before removing the radiator cap.

## THROTTLE CONTROLS

### HAND THROTTLE AND ENGINE STOP CONTROL

The hand throttle is shown in Figure 7. Pull the throttle rearward to increase engine rpm. Push the throttle forward to decrease engine rpm. Push the throttle full forward to stop the engine.

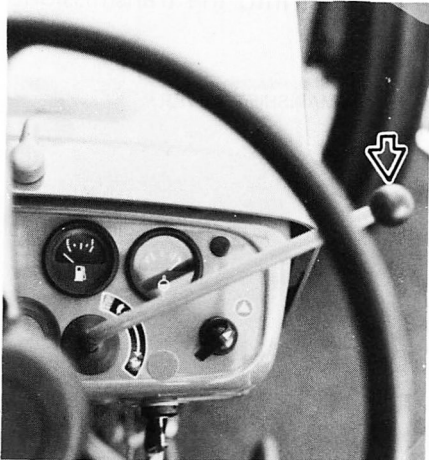

Figure 7 – Hand Throttle

## FOOT THROTTLE

The foot throttle, shown in Figure 8, can be used separately, or in conjunction with the hand throttle. With the hand throttle control lever set at a selected engine rpm, the foot throttle can be used to increase engine rpm to its maximum speed. Upon release of the foot throttle, the engine speed will return to idle or to the rpm at which the hand throttle has been set.

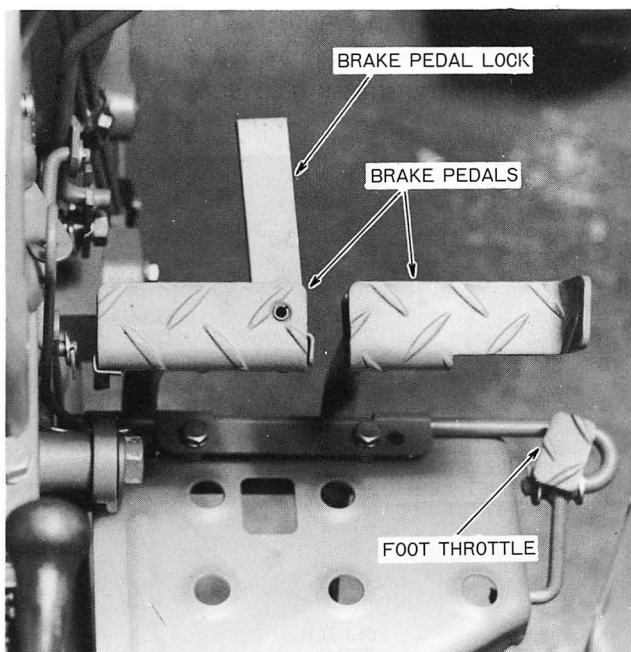

Figure 8 – Foot Throttle and Brake Controls

## BRAKE CONTROLS

### BRAKE PEDALS

The brake pedals are shown in Figure 8. The right brake pedal is used to brake the right rear wheel. The left pedal is used to brake the left rear wheel. Depress both pedals simultaneously to stop the tractor.

To assist in making sharp turns at slow speeds, depress the right or left brake pedals as required.



**WARNING:** When operating the tractor at high speeds, never attempt to make sharp turns by using the brakes.

### BRAKE PEDAL LOCK

The brake pedal lock, shown in Figure 8, is used to secure the brake pedals together. Lock the pedals together whenever the tractor is operated at high speeds and at any time the tractor is used on the highway.

### PARKING BRAKE CONTROL

The parking brake control, shown in Figure 9, is used for locking the brake pedals in the applied position. The parking brake should be applied whenever the tractor is parked.

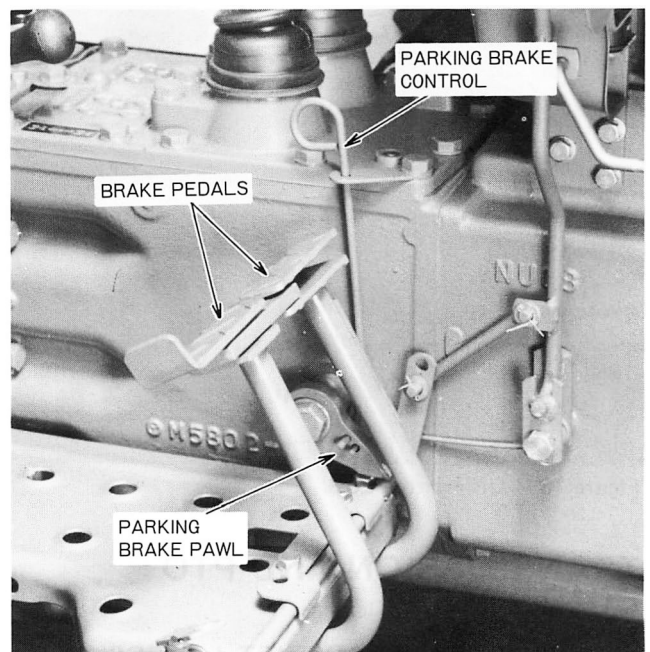

Figure 9 – Parking Brake Control

# CONTROLS AND INSTRUMENTS

To apply the parking brake:

- Lock the brake pedals together with the brake pedal lock.
- Depress both brake pedals.
- Pull up on the parking brake lever. The pawl on the control will engage the teeth on the left-hand brake pedal and will retain the pedals in the applied position.

To release the parking brake:

- Depress the brake pedals to release the pawl.
- Unlock the brake pedals if operating conditions require independent rear wheel braking action.

## DIFFERENTIAL CONTROL

### DIFFERENTIAL LOCK PEDAL

The differential lock pedal is shown in Figure 10. Depressing the pedal locks the rear axle shafts together, providing additional traction in wet or loose soil. Refer to page 17 for differential lock operating information.



**WARNING:** Tractor is very difficult to steer with differential locked.

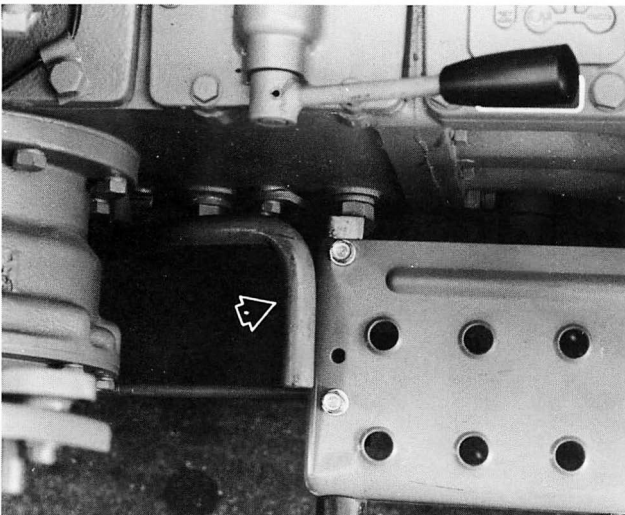

Figure 10 – Differential Lock

## TRANSMISSION AND PTO CONTROLS

### TRANSMISSION GEARSHIFT LEVERS

The transmission main shift lever and range selec-

tor lever are shown in Figure 11. A diagram showing the shift pattern is cast into the transmission cover.

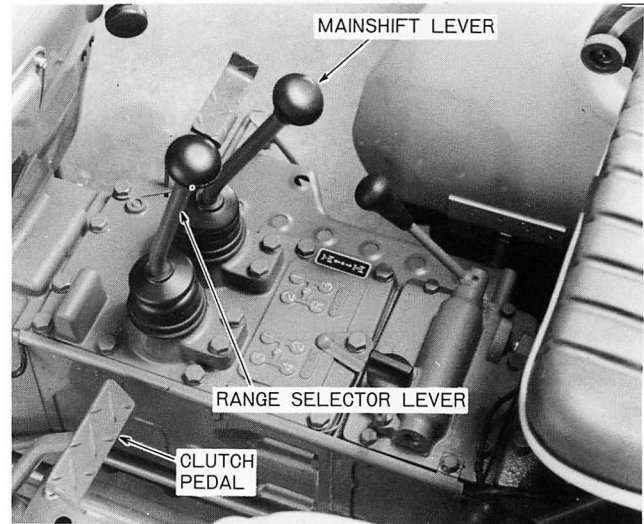

Figure 11 – Transmission Controls

Three forward and one reverse speed are provided for each of the four ranges. This provides a total of 12 forward and 4 reverse speeds.

### SYNCHROMESH TRANSMISSION GEARSHIFT LEVERS – (OPTIONAL)

The transmission main shift lever and range selector lever are shown in Figure 12. A diagram showing the shift pattern is provided on the shuttle shift cover and transmission cover.

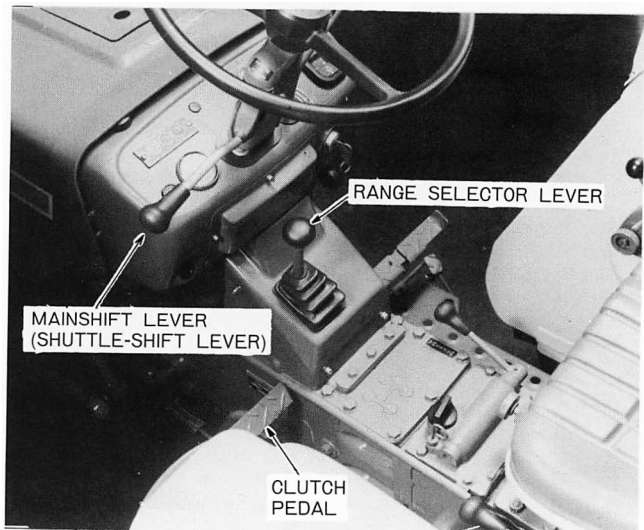

Figure 12 – Synchromesh Transmission Controls

Three forward and one reverse speed are provided for each of the four ranges. This provides a total of 12 forward and 4 reverse speeds.

## CREEPER RANGE (ACCESSORY)

A creeper range accessory with a 6.63:1 ratio is available which provides an additional 12 forward and 4 reverse speeds or a total of 24 forward and 8 reverse speeds. The control is located on the top, left-hand front of the rear-axle center housing. Full downward movement of the lever engages the creeper range. Full upward movement disengages it.

## FOUR-WHEEL DRIVE (OPTIONAL)

The shift lever for the four-wheel drive is located on the top right-hand front of the rear-axle center housing, Figure 13.

Full downward on the lever disengages the four-wheel drive (OFF). Full upward engages the four-wheel drive (ON).

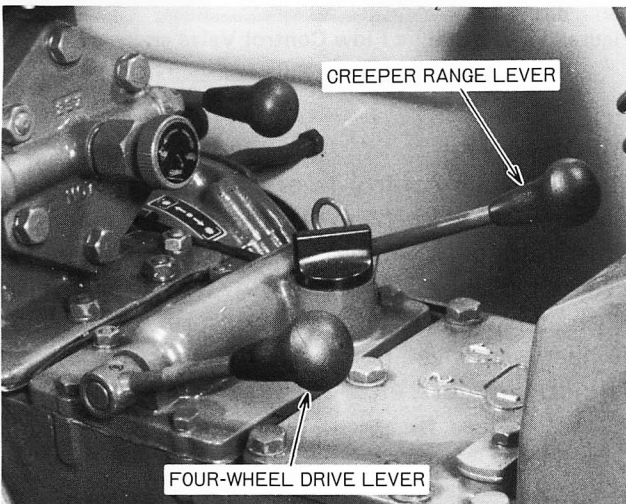

Figure 13 – Four-Wheel Drive Lever (Optional)

## CLUTCH PEDAL

The foot-operated clutch pedal, Figure 14, must be completely depressed to start the tractor or to stop forward travel and P. T. O. shaft rotation. Always fully depress the pedal when changing gear ratios or engaging four-wheel drive or creeper range.

## DUAL CLUTCH (OPTIONAL)

A dual clutch option is available which allows stopping tractor movement while the P. T. O. shaft continues rotation.

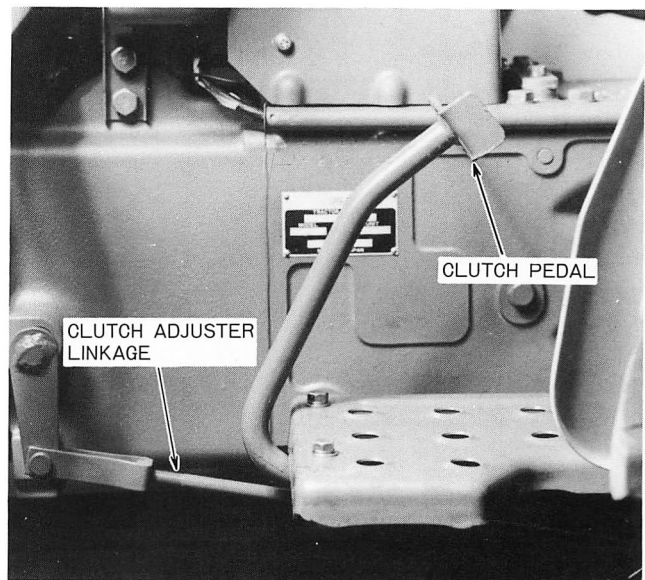

Figure 14 – Clutch Control

When the clutch pedal is depressed to position (1), Figure 15, the tractor movement stops while the P. T. O. shaft continues rotation (if the P. T. O. is engaged). If the pedal is depressed completely (2), both tractor and P. T. O. motion stop.

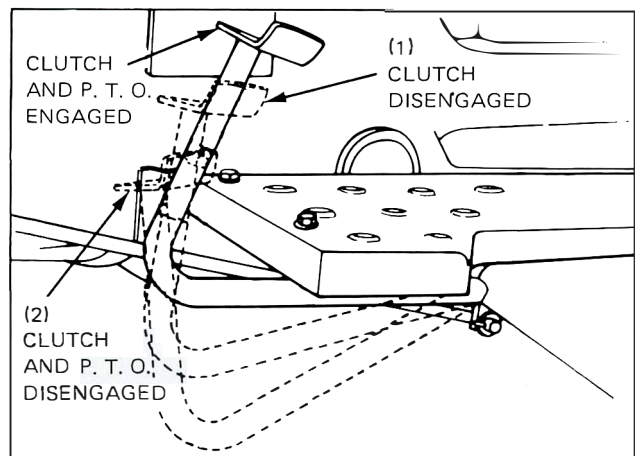

Figure 15 – Dual Clutch (Optional)

## TRANSMISSION P. T. O. CONTROL LEVER

The transmission P. T. O. control lever is shown in Figure 16. The lever engages and disengages the P. T. O. If the tractor engine is running, always depress the clutch pedal fully before moving the lever. Move the lever rearward or up to engage the P. T. O. and forward or down to disengage the P. T. O.

# CONTROLS AND INSTRUMENTS

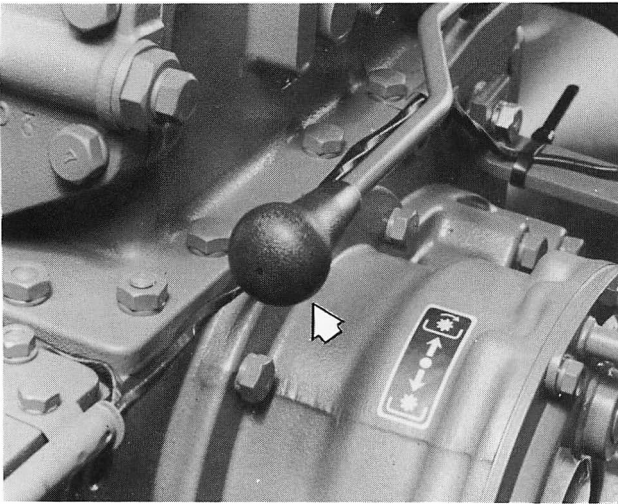

Figure 16 – P. T. O. Control

## HYDRAULIC LIFT SYSTEM CONTROLS

### HYDRAULIC LIFT CONTROL LEVER

The hydraulic lift control lever is shown in Figure 17. The lever is located at the right hand side of the seat. To lower the lift arms, push the lever forward. The adjustable stop is provided for returning the lever to a pre-set position in the quadrant. To raise the lift arms, pull lever rearward. The flow control valve must be opened before the hydraulic lift control will function.

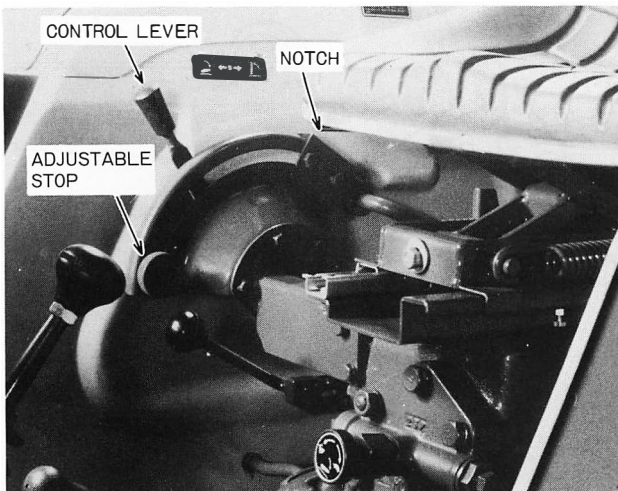

Figure 17 – Hydraulic Lift System Control

### FLOW CONTROL VALVE

The flow control valve is shown in Figure 18. Turning the valve "in" (clockwise) will decrease the lowering speed of the lower links, and turning the valve "out" (counterclockwise) will increase the lowering speed of the lower links. Refer to

"FLOW CONTROL," page 18, for additional information on operating the flow control valve.

### AUXILIARY SERVICE PORT

The auxiliary service port, Figure 18, may be utilized to supply oil to an externally mounted hydraulic cylinder. Oil will be supplied to the cylinder when the lift control lever is placed in the notch at the upper part the quadrant, Figure 17.

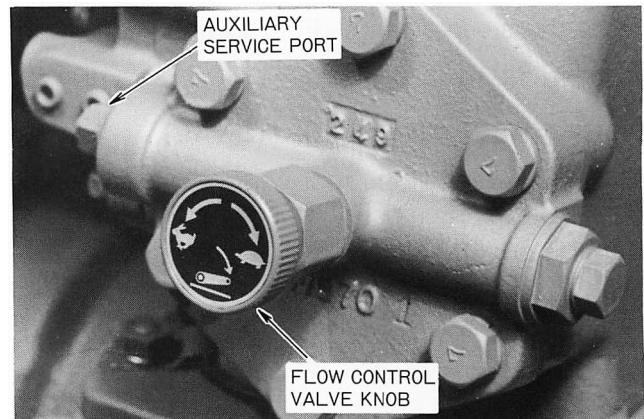

Figure 18 – Hydraulic Flow Control Valve and Auxiliary Service Port

### IMPORTANT:

The hydraulic control lever should not be positioned in the notch at the top of the quadrant when raising the tractor hydraulic linkage. The lever should be positioned in the notch only when taking hydraulic oil pressure out of the auxiliary service port for external hydraulic cylinders, motors, etc.

## DRAFT AND POSITION CONTROL LEVERS (OPTIONAL)

The hydraulic lift control levers are shown in Figure 19. The levers are located at the right hand side of the seat. The outer lever is position control lever, the inner lever is the draft control lever. The position control lever is used to raise or lower the hydraulic lift arms. To raise the lift arms, pull the lever upward. To lower the lift arms, push the lever downward. The adjustable stop is provided for locating the lever at any position in the quadrant. The draft control lever is used to adjust the draft load. The lift arms are raised by light draft loads when the lever is pulled upward, and by heavy draft loads when the lever is pushed down.

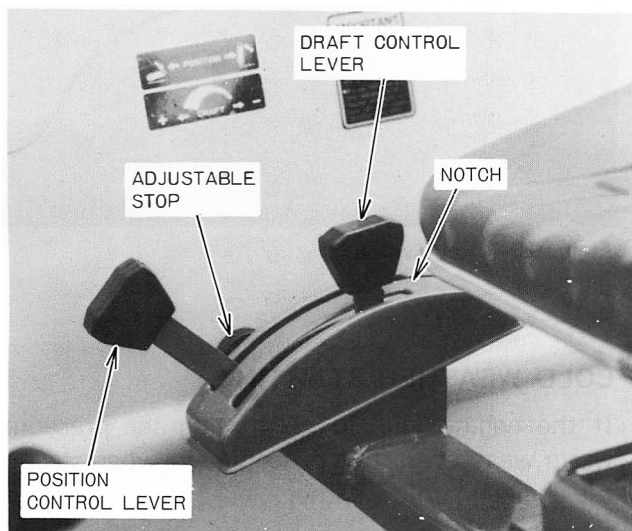

**Figure 19 – Hydraulic Life System Control – Draft and Position Control (Optional)**

## REMOTE CONTROL VALVES – OPTIONAL

Two types of remote control valves are available for your Ford Tractor. A single or double spool valve is available to operate one or two remote cylinders for rear-mounted implements.

Refer to page 21 for operating instructions.

## HYDRAULIC MANIFOLD BLOCK

Your Ford Tractor is equipped with a hydraulic manifold block, which can be utilized to supply oil to hydraulic equipment such as a front loader, dozer blade, etc.

Refer to "OPERATING HYDRAULIC MANIFOLD BLOCK" on page 21.

# OPERATION

## BREAK-IN PROCEDURES

Your Ford Tractor will provide long and dependable service if given proper care during the 50-hour break-in period. During the first 50 hours of operation:

1. Avoid "lugging" the engine. Operating in too high a gear under heavy load may cause engine "lugging", which is indicated when the engine will not respond to a throttle increase.
2. Use the lower gear ratios when pulling heavy loads and avoid continuous operation at constant engine speeds. You will save fuel and minimize engine wear by selecting the correct gear ratio for a particular operation. Operating the tractor in low gear with a light load and high engine speed will waste fuel.
3. Avoid prolonged operation at either high or low engine speeds without a load on the engine.
4. Check the instruments frequently and keep the radiator and oil reservoirs filled to their recommended levels. Daily checks include:
  - Engine oil level
  - Radiator coolant
  - Air cleaner

## STARTING THE ENGINE

A safety key switch on the tractor allows the starting motor to be used only when the main shift lever is in neutral position. For safe operation the range selector lever and P. T. O. lever should be in neutral position prior to starting the engine.



**WARNING:** Never attempt to start the engine while standing beside the tractor — always sit in the seat when starting the engine.

**IMPORTANT:** Do not engage the starting motor continuously for more than 30 seconds; doing so may cause starting motor failure.

### WARM WEATHER STARTING

To start a cold engine in warm weather or to start an engine that is warm:

1. Depress the clutch pedal fully and move the shift lever to the neutral position.
2. Move the hand throttle rearward to a near full open position.

3. Turn the key switch to the "start" position, Figure 20. When the engine starts, release the key. Check to be sure the warning lights go out. If the engine fails to start after cranking for approximately 10 seconds, refer to the following "COLD WEATHER STARTING" information.

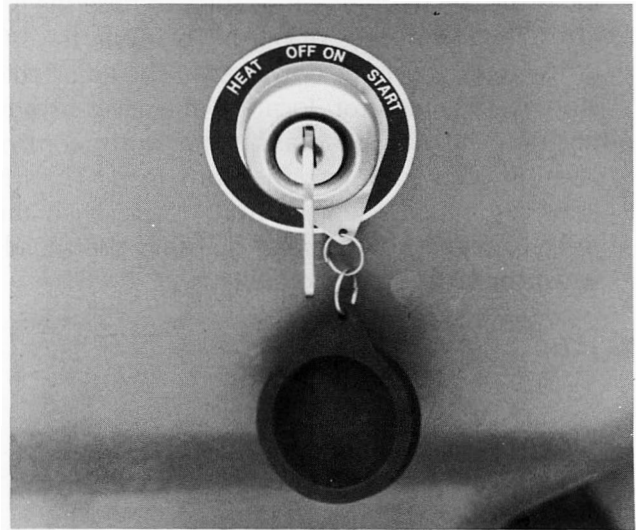

Figure 20 — Key Switch

### COLD WEATHER STARTING

If the engine fails to start using the preceding warm weather starting procedure or when starting the engine in cold weather:

1. Depress the clutch pedal fully and move the shift lever to the neutral position.
2. Move the hand throttle rearward to the wide-open position.
3. Turn the key switch to "heat" to preheat the precombustion chambers and wait until the cold-start aid indicator shows red (approximately 20 seconds).
4. Turn the key switch to the "start" position. When the engine starts, release the key. Check to be sure the warning lights go out.



**WARNING:** Do not use ether with the thermostart starting aid.

**NOTE:** A coolant immersion heater which provides for easier starting in temperatures below 0°F (-17.7°C) by warming the engine oil and coolant is available as a dealer installed option.

## STARTING THE TRACTOR WITH JUMPER CABLES



**WARNING:** Start engine only from operator's seat. If safety start switch is bypassed, engine can start with transmission in gear.

If it is necessary to use jumper cables to start the tractor, follow the instructions below.

1. Shield eyes.
2. Connect one end of the jumper cable to the tractor battery positive (+) terminal and the other to the auxiliary battery positive (+) terminal. Connect one end of the other cable first to the auxiliary battery (–) negative terminal, and the other end to the tractor starter ground terminal. Follow the starting procedures above after the jumper cables are connected as instructed.

Idle the engine and turn on all electrical equipment (lights, etc.), then disconnect the cables in reverse order of the connecting procedure above. This will help protect the alternator from damage due to extreme load changes.



**WARNING:** Batteries contain sulfuric acid and produce explosive gases. Follow the instructions below to prevent personal injury.

- Wear eye and skin protection.
- Keep sparks and flame away.
- Always have adequate ventilation while charging or using the battery.
- Follow the battery manufacturer's instructions which are shown on the battery.

## STOPPING THE ENGINE

Push the hand throttle fully forward past idle position to stop the engine, then turn the key switch, Figure 20, to the "Off" position.

**IMPORTANT:** Failure to turn the key switch to the "Off" position after the engine stops will allow the warning lights to remain on, causing the battery to discharge.

## OPERATING THE TRANSMISSION, FOUR-WHEEL DRIVE AND PTO

### 12 X 4 TRANSMISSION

The transmission operates through the use of a clutch pedal, a main shift lever and a range selector lever. Figure 21 illustrates the pedal and levers involved. Ground speeds for the various gear ratios can be found on page 55. Figure 22 shows the combinations of main shift lever and range selector lever positions to obtain the 12 forward and four reverse speeds.

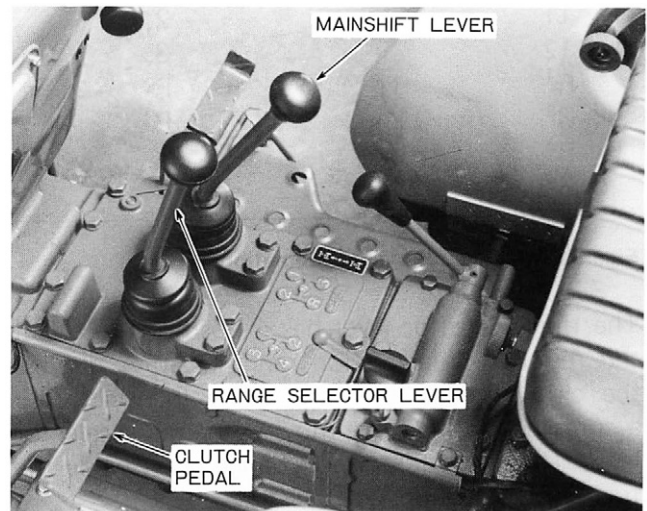

**Figure 21 – Transmission Controls and Shift Pattern**

When in motion, always depress the clutch pedal fully and bring the tractor to a complete stop before moving either gearshift lever. Do not attempt to change gears while the tractor is in motion.

### 12 X 4 SYNCHROMESH TRANSMISSION

The 12 X 4 Synchronesh Transmission operates through the use of a clutch pedal, a shuttle shift lever, and a range selector lever. Figure 23 illustrates the pedal and levers involved. Ground speeds for the various gear ratios can be found on page 55. Figure 22 shows the combinations of shuttle shift lever and range selector lever positions to obtain the 12 forward and four reverse speeds.

The shuttle shift lever has four positions. Depress the clutch and press the shuttle shift lever down and push forward for 1st gear, pull rearward for 3rd gear. Lift the lever, pull rearward for reverse gear and forward for 2nd gear. Any of these ratios may be selected with the tractor moving or stationary provided the clutch is depressed.

# OPERATION

SPEED	RANGE	MAIN (SHUTTLE)
1	1	1
2		2
3		3
4	2	1
5		2
6		3
7	3	1
8		2
9		3
10	4	1
11		2
12		3
R <sup>1</sup>	1	R
R <sup>2</sup>	2	R
R <sup>3</sup>	3	R
R <sup>4</sup>	4	R

**Figure 22 – Speed Range Combinations**

The range selector lever has 4 positions to select the required transmission range. Always depress the clutch pedal fully and bring the tractor to a complete stop before moving the range selector lever. Do not attempt to change gears while the tractor is in motion.

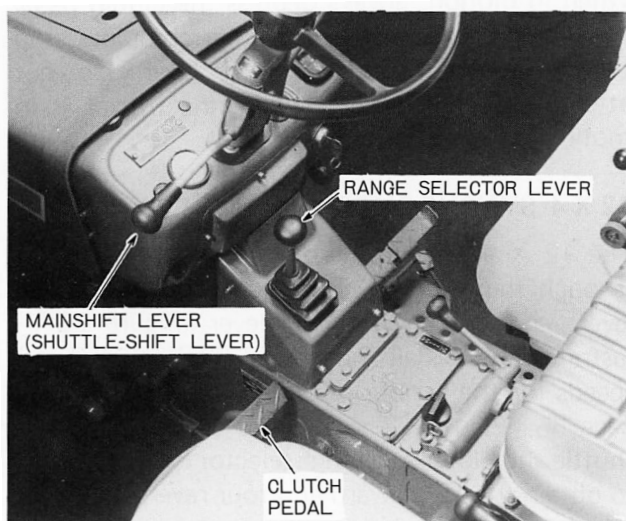

**Figure 23 – 12 X 4 Synchronmesh Transmission Controls and Shift Pattern**

**IMPORTANT:** Avoid using the clutch pedal as a “footrest” (riding the clutch). Prolonged operation in this manner can cause damage to the clutch components.

**IMPORTANT:** When shifting down on the go, shift through each gear sequence. Skipping gears while down shifting can damage components due to over speed.

## FOUR-WHEEL DRIVE

The four-wheel drive is engaged and disengaged through the use of the lever on the top right-hand front of the rear-axle center housing, Figure 13.

To engage the four-wheel drive, depress the clutch pedal fully and move the four-wheel drive lever fully upward. To disengage, move the lever full downward.



**WARNING:** Do not operate the tractor in front-wheel drive while driving on roads or at high speeds.

## IMPORTANT:

The front wheel drive should be used only when additional traction is required while operating in loose soil, wet, slippery conditions or on slopes. For normal operation on firm soil, hard surfaces and roading the unit, front wheel drive should be disengaged to maximize tire and driveline life and fuel economy.

## POWER TAKE-OFF

The power take-off (P. T. O.) in your tractor transfers engine power directly to mounted or pull-type P. T. O. equipment. The standard P. T. O. speed is 540 ± 10 rpm. Most P. T. O. equipment is designed to operate efficiently at this speed. This speed is obtained when engine rpm is set at 2422 rpm, as indicated by the P. T. O. symbol on the Proof-Meter rpm scale.

**IMPORTANT:** Do not exceed 2422 rpm engine speed when operating P. T. O.-driven equipment.

The transmission P. T. O. is controlled through a lever shown in Figure 16. The transmission P. T. O. can be engaged, operated, and disengaged as described under “POWER TAKE-OFF OPERATION.”

**IMPORTANT:** Optional drawbar is required to provide standard P. T. O. drawbar relationship, Figure 24.

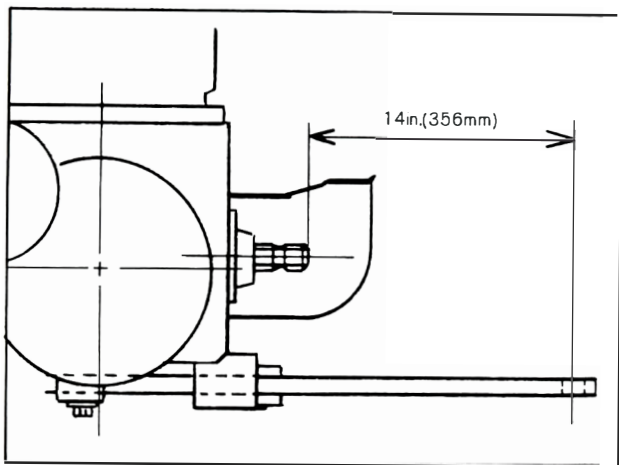

**Figure 24 – Drawbar Settings for P. T. O. Operation**

### P. T. O. SHIELD AND CAP

The P. T. O. shield, shown in Figure 25, is standard equipment. The shield is to be used with both mounted and pull-type equipment. The P. T. O. cap should always be installed when the P. T. O. is not in use.

**! WARNING**

- Pull only from drawbar. Pulling from any other point can cause rear overturn.
- Do not operate with unshielded PTO. ● Disengage PTO and stop engine before servicing tractor or implements or attaching and detaching implements.
- Position drawbar at 14" from end of PTO shaft to drawbar hole for 540 and 16" for 1000 PTO RPM. ● When towing equipment use a safety chain.

FAILURE TO FOLLOW ANY OF THE INSTRUCTIONS ABOVE CAN CAUSE SERIOUS INJURY TO THE OPERATOR OR OTHER PERSONS.

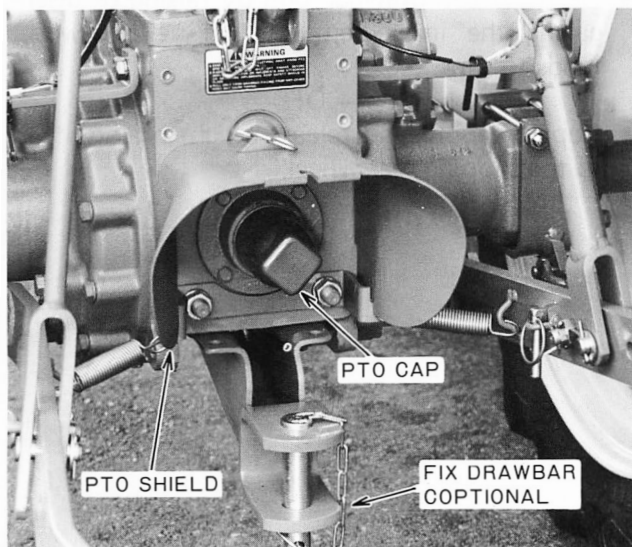

**Figure 25 – P. T. O. Shield and Cap**

### POWER TAKE-OFF OPERATION

1. Attaching the P. T. O.



**WARNING:** To reduce the possibility of personal injury comply with the following before attaching or detaching P. T. O. equipment, and before working on or clearing P. T. O. equipment.

- Stop the engine.
- Depress the clutch pedal completely and move the transmission gearshift lever to the neutral (N) position.
- Set parking brake.
- Disengage the P. T. O. with the P. T. O. control lever, Figure 16.
- Remove the P. T. O. cap.
- Wait until the P. T. O. shaft stops turning.
- Attach the mounted or drawn equipment. Make sure the equipment-driven shaft is properly aligned and locked to the tractor P. T. O. drive shaft and that the P. T. O. shield is installed on the tractor.

2. With the P. T. O. disengaged, start the engine. In the case of mounted equipment, raise and lower the equipment to make sure proper clearances exist.

3. With the transmission in neutral, depress the clutch pedal completely, then engage the P. T. O. by moving the P. T. O. control lever, Figure 16, up or rearward.

**NOTE:** Failure to move the P. T. O. lever through its full range may result in damage to the P. T. O.

4. Check the P. T. O.-driven equipment for proper operation by gradually releasing the clutch pedal and increasing engine rpm.

5. After determining that the equipment is operating properly, depress the clutch pedal and shift to the desired operating gear. Release the pedal gradually to start the P. T. O. and tractor in motion.

## OPERATION

- Control the P. T. O. speed with the throttle, never exceeding 2422 rpm. If the tractor movement is too fast for the P. T. O. load, stop the tractor and shift to a lower gear.
- Disengage the P. T. O. with the P. T. O. control lever when making sharp turns with pull-type equipment and with mounted equipment in the fully raised position.
- Disconnect the P. T. O.-driven shaft at the tractor P. T. O. shaft before traveling on highways or for any great distance.
- Reinstall the P. T. O. shaft cap when the P. T. O.-driven equipment is disconnected from the tractor or when the P. T. O. is not being used.



**WARNING:** To avoid inadvertent movement of P.T.O. implement, disengage P.T.O. after each use.

### TOWING THE TRACTOR

To tow your tractor, place the transmission gear-shift levers in neutral. Do not exceed 12 mph (20 kph). Do not tow your tractor to start it.

If the tractor is to be moved any great distance, use a solid tow bar and pull the tractor at a speed not to exceed 12 mph (20 kph).



**WARNING:** For safety reasons, towing the tractor on the highway is not recommended. Also, for safety reasons, never attempt to start the engine by towing.

### OPERATING THE DIFFERENTIAL LOCK

The differential lock is engaged by depressing the pedal located on the right side of the rear axle center housing, Figure 26. Depressing the pedal locks both final drive pinion gear shafts together, preventing one wheel from rotating independently of the other. The lock should be used to obtain additional traction from the opposite wheel whenever one wheel begins to slip in wet or loose soil.

Do not engage the differential lock when driving the tractor on the highway or when ground speed is above 5 mph (8 kph).

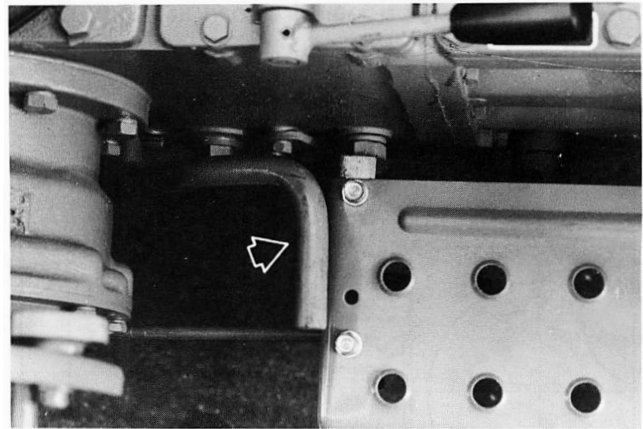

**Figure 26 – Differential Lock Pedal**



**WARNING:** Do not engage the differential lock when turning the tractor. If the lock is engaged when turning, a loss of steering control will result.

To operate the differential lock, depress and hold down the pedal until the lock is positively engaged. It is best to engage the differential lock while the wheels are turning slowly to minimize shock loads to the drive line. If a wheel spins at high speed, as on ice, reduce engine speed to idle before engaging the lock, or damage may occur. The differential lock is released by releasing the pedal.

**NOTE:** In some instances the lock may remain engaged after the pedal is released. This may occur if one rear wheel tends to turn at a faster speed than the other. Should this happen, the lock may be disengaged by either of two ways:

- Decrease the drawbar pull by raising or disengaging the implement so that neither wheel tends to slip.
- OR –
- Rapidly apply and release a light braking load to the slipping rear wheel.

## OPERATING THE HYDRAULIC LIFT SYSTEM

### SINGLE LEVER HYDRAULIC LIFT SYSTEM (STANDARD)

The hydraulic lift system provides accurate, smooth, and instant hydraulic power for raising a variety of compatible equipment whenever the engine is running. The position control feature of the system maintains the selected height or depth of three point linkage equipment in relation to the tractor. When the hydraulic lift control lever is moved to a higher or lower setting in the quadrant, the system repositions the equipment to a higher or lower position and maintains the selected position, Figure 27.

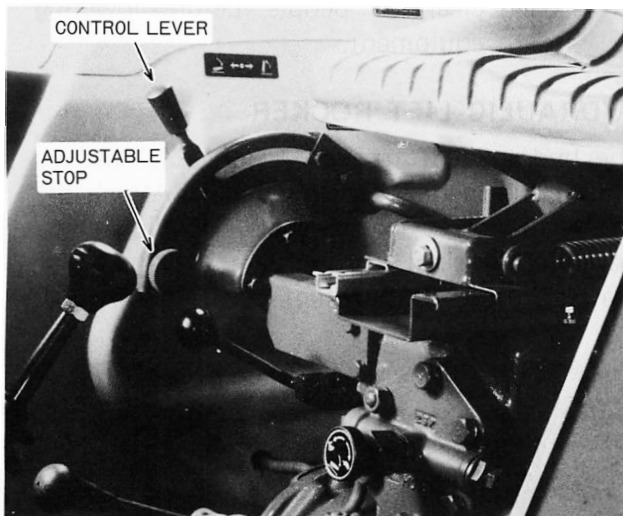

Figure 27 – Hydraulic Lift System Control

### TWO LEVER HYDRAULIC LIFT SYSTEM WITH DRAFT AND POSITION CONTROL (OPTIONAL)

If your tractor is equipped with the optional Two Lever Control System shown in Figure 28, there are two modes of Hydraulic Lift System operation—Position Control or Draft Control—that can be selected to satisfy operating conditions for the implement being used.



**WARNING:** Make sure area is clear of people before lowering equipment.

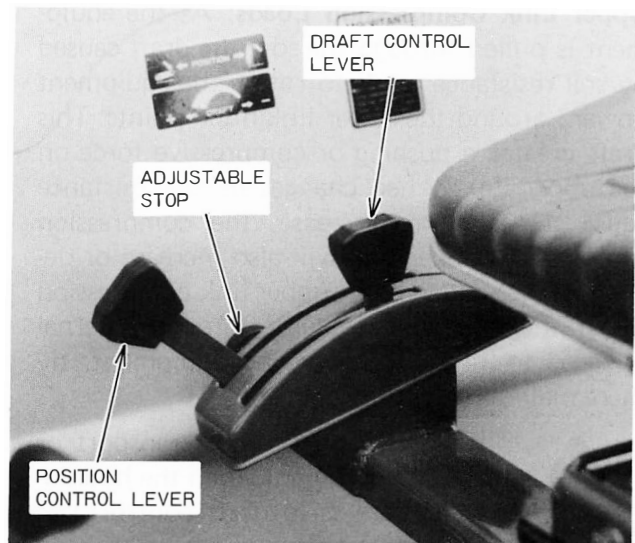

Figure 28 – Two Lever Hydraulic Lift system Control (Draft and Position)

### POSITION CONTROL

When operating in position control, there is a definite relationship between the position of the control lever in the quadrant and the position of the equipment. The lever must be moved to change the position of the equipment relative to the tractor. The system will automatically maintain the equipment in the selected position.

Position control provides easy, accurate control of three-point linkage equipment that operates above the ground; such as sprayers, rakes, mowers, etc. It also provides a uniform depth when using a blade or similar equipment on level ground.

The position control lever (Outer) is used to raise and lower the equipment.

### DRAFT CONTROL

When operating in draft control, the lift control lever is used to adjust the draft load. Once the lever is positioned, the hydraulic lift system will automatically adjust the depth of the equipment to maintain an even load on the tractor as soil conditions vary. The hydraulic system senses draft-changes through changes in upper link compression. The operation of the upper link draft sensing system is described on the next page.

# OPERATION

---

**Upper Link Compression Loads:** As the equipment is pulled through the soil, the draft caused by soil resistance tends to rotate the equipment upward around the lower link hitch points. This draft creates a pushing or compressive force on the upper link. When changes in soil resistance cause the draft to increase, the compression force on the upper link will also increase or decrease. These changes in upper link compression signal the hydraulic system, through internal linkage, to raise or lower the equipment, by there maintaining uniform draft.



**WARNING:** Do not transport or attach equipment when the hydraulic system is in draft control. Use position control.



**WARNING:** Always lower the hydraulic lift and all other hydraulic equipment before stopping the tractor.

Ford tractors having the Hydraulic Draft Control option are equipped with two lever hydraulic lift control systems. The operation of each system is described below:

## TWO LEVER CONTROLS POSITION CONTROL OPERATION

The two lever control system is shown in Figure 28. Position control is obtained by placing the inner (draft) control lever in the down position and then moving the outer (Position) control lever to position the equipment as desired. The outer (position) lever is used to rise or lower the equipment.

## DRAFT CONTROL OPERATION

Draft control is obtained by placing the position control lever in the down position. Use the draft control to adjust the draft setting (the lift system will automatically maintain the selected draft as described above.)

## OPERATING IN BOTH POSITION AND DRAFT CONTROL

The position control may be used together with the draft control as follows:

1. Set the position control lever at the maximum desired implement depth. The hydraulic system will not lower the implement below the preselected depth. (This will also prevent "diving" which may be encountered with light equipment, such as a rear blade, when grading or backfilling.)
2. Adjust the draft control lever for the maximum draft load (pull) desired.

The hydraulic lift system will now provide normal draft response within the range set by the position control. This adjustment provides a more uniform depth while maintaining an even pull in widely varying soil conditions.



**WARNING:** Make sure the area is clear of people before lowering equipment.

## HYDRAULIC LIFT ROCKER

The hydraulic lift rocker, Figure 29, has two holes for attaching the upper link. Attach the link in the lower hole, as shown, for light draft loads (cultivating) and in the top hole for heavier draft loads (plowing).

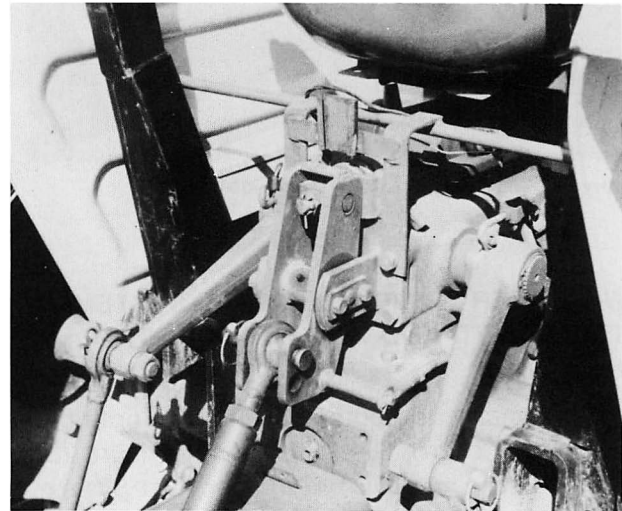

Figure 29 – Hydraulic Lift Rocker

## FLOW CONTROL VALVE

The flow control valve, Figure 30, provides an adjustment to regulate the flow of oil from the lift cylinder, thus slowing or increasing the rate of drop of the lower links. To adjust rate of flow, either turn the flow control valve "in" (clockwise) to decrease the rate of drop or "out" (counterclockwise) to increase the rate of drop. The flow control valve must be opened before hydraulic lift control will function.

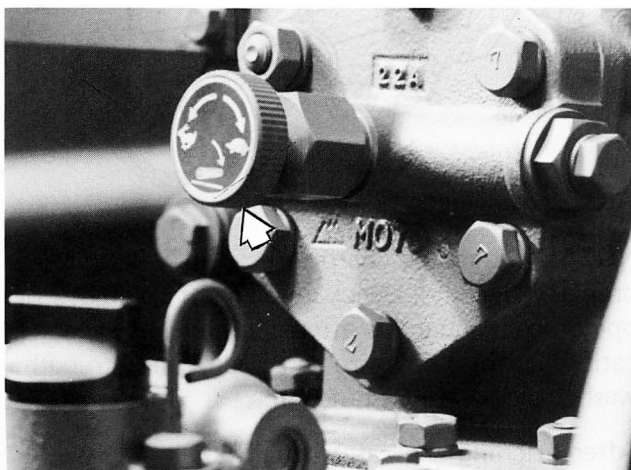

Figure 30 – Flow Control Valve

## OPERATING REMOTE CONTROL VALVES (OPTIONAL)

Your Ford Tractor can be equipped with a single or double spool remote control valve. See Figure 31. Pull the control lever rearward to extend the cylinder. Push the control lever forward to retract the cylinder. Release the control lever to stop the cylinder in any position before it is fully extended. The lever returns to neutral automatically.

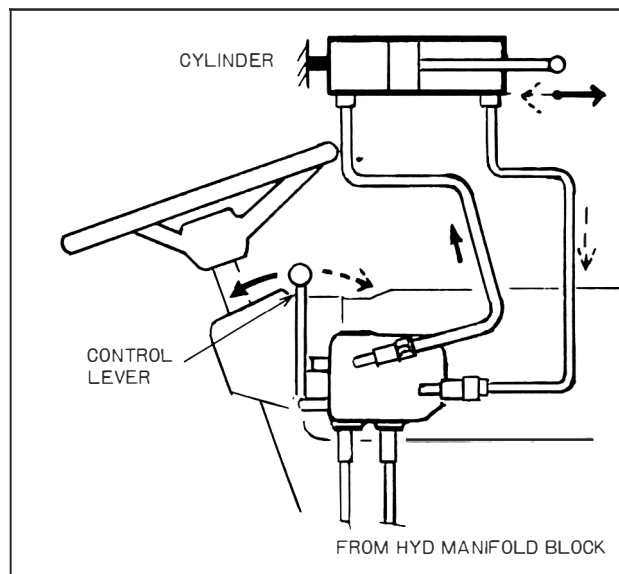

Figure 31 – Remote Control Valve

## OPERATING HYDRAULIC MANIFOLD BLOCK

The hydraulic Manifold Block is provided to supply hydraulic oil to equipment such as a front loader, dozer blade, etc. Location of the Block is shown in Figure 32.

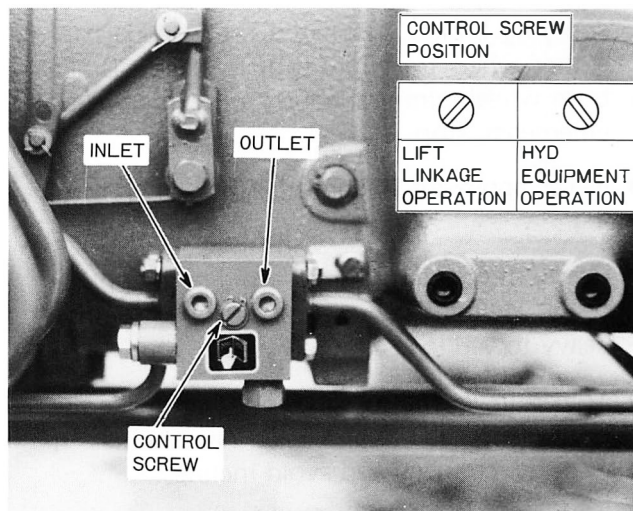

Figure 32 – Hydraulic Manifold Block

# OPERATION

---

## DRIVING THE TRACTOR



**WARNING:** Observe the following precautions when driving the tractor.

- Watch where you are going — especially at row ends, on roads, and around trees.
- Keep the tractor in gear when going down hill. Use a low gear to maintain control with minimum braking.
- If the tractor is stuck, back out to prevent upsetting the unit.
- Always use the drawbar for pull-type work. Do not pull from any other part of the tractor since it may tip backward.
- Keep the lights adjusted so they do not blind the operator of an oncoming vehicle.
- Engage the clutch slowly when driving out of a ditch, gully, or up a steep hillside. Engage the clutch promptly should the front wheels rise off the ground.
- Reduce speed before turning quickly or applying brakes. Lock the brake pedals together when traveling at high speeds. Brake both wheels simultaneously when making an emergency stop.
- Never apply the differential lock when turning.
- Use extreme caution and avoid hard applications of the tractor brakes when pulling heavy towed loads at road speeds.
- Towed loads that weigh more than twice the weight of the tractor should have brakes. If not, reduce speed and avoid inclines.
- Always sit in the driver's seat while starting or driving the tractor.
- Always use a slow moving vehicle (SMV) emblem and turn on flasher lights when traveling on public roads.

**IMPORTANT:** Also, when attaching close-mounted equipment to the tractor, remove the

swinging drawbar. When transporting on the highway, it is recommended that a safety chain with tensile strength equal to the gross weight of the implement be connected between the tractor and the towed implement. This will control the implement in the event the hitch pin is lost.

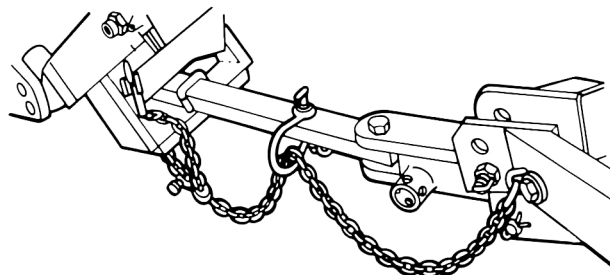

**NOTE:** Attaching hardware will need to be procured locally. Check implement assembly or operators manual for attaching hardware specifications, such as bolt size and grade, chain strength, washers, lockwasher, nuts, etc.

After attaching the safety chain, make a trial run by driving the tractor to the right and to the left for a short distance to check the safety chain adjustment. If necessary, readjust to eliminate tight or loose chain. Safety chains and suitable hardware are available from your Ford Tractor dealer.

## WHEEL TREAD SETTINGS

### FRONT WHEEL TREAD SETTINGS (TWO-WHEEL DRIVE ONLY)

The front wheel tread setting is adjustable from 43.5 to 57.5 in. (110.5 – 146 cm) by a combination of repositioning the front axle and reversing the front wheels. See Figure 30. Turf tire tread setting is 46.9 – 56.9 in. (119 – 144.5 cm).

**IMPORTANT:** It is not recommended that the front wheels be set at maximum tread width in rough terrain because of high steering wheel effort and kickback.

To reposition the front axle;

1. Set parking brake and raise the front of the tractor with a jack placed under the center of the front axle. Support with safety stands.
2. Remove the setting bolt from the tie rod.

3. Remove the adjusting bolts, Figure 33, and move the axle sections in or out until the desired setting is obtained, then reinstall the adjusting bolts.
4. Position the front wheels in the straight ahead position, then reinstall the tie rod setting bolt.
5. Check the toe-in as outlined on page 46.

**IMPORTANT:** Never attempt to widen the tread setting by reversing front wheels on a four-wheel drive system.

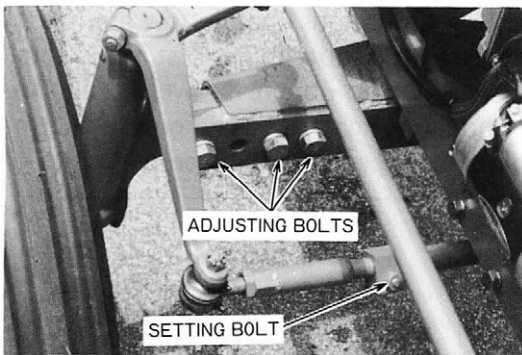

WHEEL HUB SETTING POSITION SIDE AXLE POSITION		
	43.5 INCHES (110.5 cm) (STD.)	47.4 INCHES (120.5 cm)
	46.9 INCHES (119 cm)	50.8 INCHES (129 cm)
	50.2 INCHES (127.5 cm)	54.1 INCHES (137.5 cm)
	53.5 INCHES (136 cm)	57.5 INCHES (146 cm)

Figure 33 – Front Wheel Tread Settings

**NOTE:** After changing the front wheel tread setting, the wheel disc to hub bolts should be torqued to 43-54 lbs.ft. (58-73 N.m), side axle adjusting bolts should be torqued to 177-199 lbs.ft. (240-270 N.m) and the tie rod setting bolt should be torqued to 31-41 lbs.ft. (42-55 N.m)

## REAR WHEEL TREAD SETTINGS

The rear wheels on the Ford 1710 are adjustable from 43.3 to 58.7 inches (110-149 cm). Tread width settings are made by changing the position of the rim with respect to the wheel disc, by changing the position of the wheel disc with respect to the axle, and by interchanging the rear rims from side to side. Turf tire tread settings are 49.8-52 in. (126.5-132 cm). These various positions are shown in Figure 34.

**NOTE:** After changing the rear wheel tread setting, the wheel rim-to-disc nuts and the disc-to-axle nuts should be torqued to 137-159 lbs.ft. (186-215 N.m).

STANDARD	INTERCHANGE L & R WHEEL	RESET THE RIM	RESET THE RIM AND INTERCHANGE L & R WHEEL
47.8 in. (121.5cm)	54.1 in. (137.5cm)	43.3 in. (110cm)	58.7 in. (149cm)
RESET THE RIM AND THE DISC	RESET THE RIM AND THE DISC, THEN INTERCHANGE L & R WHEEL	RESET THE RIM AND THE DISC	RESET THE RIM AND THE DISC THEN INTERCHANGE L & R WHEEL
57.1 in. (145cm)	45.1 in. (114.5cm)	52.4 in. (133cm)	49.6 in. (126cm)

Figure 34 – Rear Wheel Tread Settings

## TRACTOR WEIGHTING

To obtain sufficient traction for maximum performance in heavy draft operations and to counterbalance rear mounted equipment, weight should be added to the tractor in the form of liquid ballast, cast iron weights, as shown in Figure 35 through 37, or a combination of both. Only enough weight should be added to provide good traction and stability.

Adding more weight than is needed results in unnecessary soil compaction and increased rolling resistance and thus higher fuel consumption.

**NOTE:** When adding weight, adhere to the tire load capacities. Refer to "Tire Pressure" and the "Tire Inflation Versus Permissible Load" table on page 25 through 27.

### WEIGHTING FOR STABILITY

Front end ballast may be required for stability and steering control when weight is transferred from the front wheels to the rear wheels as the implement is raised by the tractor 3-point hitch.

As a general guide:

Ballast the tractor (less implement) so that approximately 1/3 of the tractor weight is on the front wheels. For optimum traction, tractors equipped with FWD should be ballasted so 40-45 % of machine weight is on front wheels.

When a mounted implement is raised to the transport position, the front wheel reaction should be at least 20% of tractor weight.

Add additional front and ballast as required for stability during operation and transport. Tractor front end ballast may not always maintain satisfactory stability if the tractor is operated at high speed on rough terrain. Reduce tractor speed and exercise caution under these conditions.

When using front mounted equipment, add weight to the rear axle to maintain good traction and stability.



**WARNING:** If proper stability cannot be obtained within the weighting limitations below, reduce the load on the tractor until stability is obtained.

**IMPORTANT:** Do not exceed the tire load and inflation specifications in the Tire Inflation VS. Permissible Load Chart, page 27.

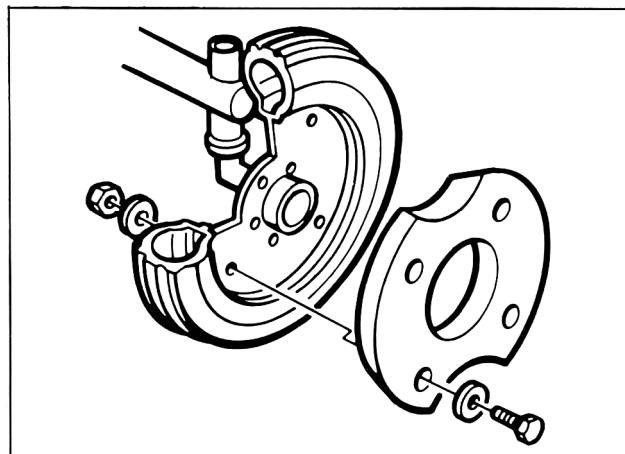

Figure 35 – Front Wheel Weights

### WEIGHTING LIMITATIONS

The weighting limitations that follow are limitations only; they do not imply that the tractor should be weighted to obtain the weights shown. Use only enough weight to obtain good performance, and do not exceed the tire load capacities.

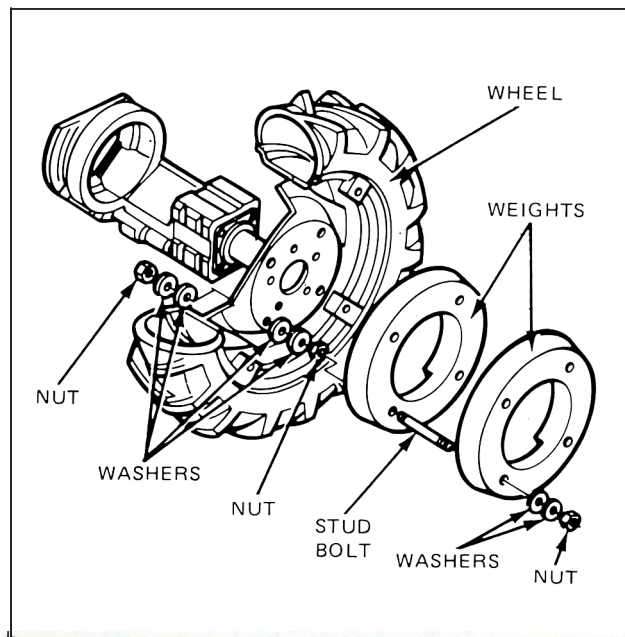

Figure 36 – Rear Wheel Weights

### TOTAL VEHICLE WEIGHT

Do not add weight exceeding the following:

- Front End – 165 lbs.
- Front Wheels – 132 lbs. (No weights on front wheels of four-wheel drive.)
- Rear Wheels – 396 lbs. plus liquid ballast.

### LIQUID BALLAST (OPTIONAL)

It is a common practice to add weight to the tractor by filling the rear tires with liquid. A calcium chloride ( $\text{CaCl}_2$ ) and water solution is recommended due to its low freezing point and greater density (weight per gallon) than water. Never exceed the total recommended weight for the tractor. Because special equipment is required to fill the tires, we recommend that you consult your Ford Tractor-Equipment Dealer. Tires should never be filled beyond 75% (tire filled to the valve stem when valve stem is at its highest point at the top of the wheel).

### CAST IRON WEIGHTS (OPTIONAL)

Cast iron weights are a factory installed option or are available as accessories from your Ford Tractor-Equipment Dealer. Weights can be mounted on the front wheels, on the front end of the tractor, and on the rear wheels as shown in Figure 35 through 37.

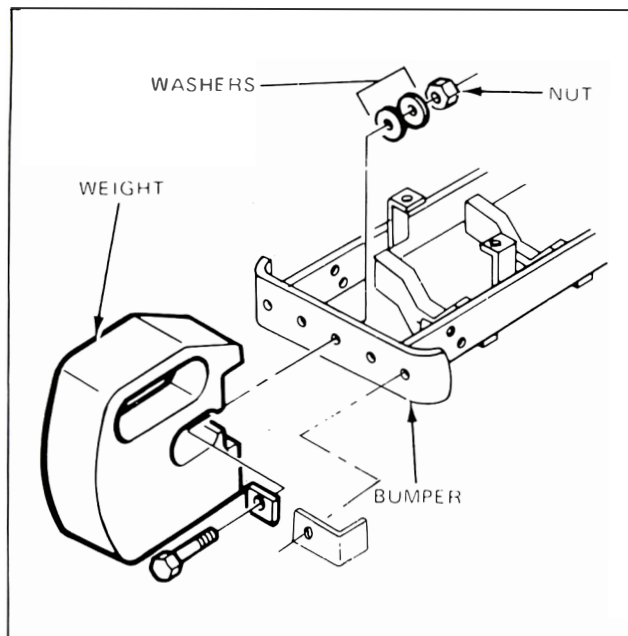

Figure 37 – Front End Weights

### TIRE PRESSURE

Tire pressure must be considered when adding weight to the tractor. The following "TIRE INFLATION vs. PERMISSIBLE LOAD" table lists the tire sizes available and shows the maximum load the tires can carry for a given air pressure. Note that the load capacities decrease as inflation pressures decrease, and also that a specific tire pressure is recommended for certain size tires.

#### TIRES

##### Inflation and Service

- Upon receiving your tractor, check the air pressure in the tires as indicated in the tables.
- Check tire pressure every 50 hours, or weekly.
- Tire inflation pressure affects the amount of weight which a tire may carry. Locate the tires for your tractor in the "TIRE INFLATION vs. PERMISSIBLE LOAD" chart on page 26. Do not over-or-under inflate the tires.
- Do not inflate a tire above the manufacturer's maximum pressure shown on the tire or the maximum pressure shown in the "TIRE INFLATION vs. PERMISSIBLE LOAD" chart, page 26 if the tire is not marked.
- Do not inflate a tire that has been runflat or seriously under-inflated until the tire has been inspected for damage by a qualified person.
- When checking tire pressure, inspect the tire for damaged side walls and tread cuts. Neglected damage will lead to early tire failure.

## OPERATION

---



**WARNING:** Inflating or servicing tires can be dangerous. Trained personnel should be called to service and/or mount tires when possible. In any event to avoid possible serious or fatal injury, follow the safety precautions below:

- Be sure the rim is clean and free of rust.
- Lubricate both tire beads and rim flanges with soap solution. Do not use oil or grease.
- Use a clip-on tire chuck with a remote hose and gauge which allows the operator to stand clear of the tire while inflating it.
- NEVER INFLATE TO OVER 35 psi (2.4 bar) TO SEAT BEADS. If beads have not seated by time pressure reaches 35 psi, deflate the assembly, reposition tire on rim, relubricate both tire beads and rim flanges and re-inflate. Inflation beyond 35 psi with unseated beads may break the bead or rim with explosive force sufficient to cause serious injury.
- After seating the beads, adjust inflation pressure to recommended operating pressure.
- Do not inflate a tire unless the rim is mounted on the tractor or is secured so that it will not move if the tire or rim should suddenly fail.
- Do not weld, braze, otherwise repair, or use a damaged rim.
- Never attempt tire repairs on a public road or highway.
- Use jack stands or other suitable blocking to support the tractor while repairing tires.
- Insure jack has adequate capacity to lift your tractor.
- Insure jack is placed on a firm level surface.
- Do not put any part of your body under the tractor or start the engine while the tractor is on the jack.
- Torque lug nuts to specification after reinstalling wheel. Check lug nut torque daily until torque stabilizes.
- Refer to tractor weighting section before adding ballast to the tires.

**TIRE INFLATION vs. PERMISSIBLE LOAD**

FRONT TIRE SIZE		INFLATION PRESSURES — psi (bar)								
		8 (.55)	10 (.69)	12 (.83)	20 (1.4)	24 (1.7)	28 (1.9)	32 (2.2)	36 (2.5)	40 (2.8)
		MAXIMUM PERMISSIBLE LOAD — lbs. (kg.)								
5.00X15	4 PR F 2	—	—	—	540 (245)	600 (272)	660 (299)	710 (322)	760 (345)	810 (367)
6.00X16	4 PR R I	—	—	—	760 (345)	840 (381)	920 (417)	—	—	—
23X8.50-12	2 PR R 3	620 (280)	705 (313)	—	—	—	—	—	—	—
27X8.50-15	2 PR R 3	775 (350)	885 (402)	—	—	—	—	—	—	—
23X8.50-12	4 PR R 3	620 (280)	705 (313)	785 (356)	1055 (479)	—	—	—	—	—
27X8.50-15	4 PR R 3	775 (350)	885 (402)	985 (447)	1325 (601)	—	—	—	—	—
		INFLATION PRESSURES — psi (bar)								
REAR TIRE SIZE		12 (.83)	14 (.96)	16 (1.1)	18 (1.2)	20 (1.4)	—	—	—	—
		MAXIMUM PERMISSIBLE LOAD — lbs. (kg.)								
11.2X24	4 PR R I	1470 (667)	1610 (730)	1740 (789)	1860 (844)	—	—	—	—	—
13.6X16	4 PR R 3	1610 (730)	1760 (798)	—	—	—	—	—	—	—

**NOTE :** Do not exceed the maximum load listed: Also, do not under-inflate or over-inflate the tires.

# LUBRICATION AND MAINTENANCE

## LUBRICATION AND MAINTENANCE CHART — FORD 1710 TWO-WHEEL DRIVE

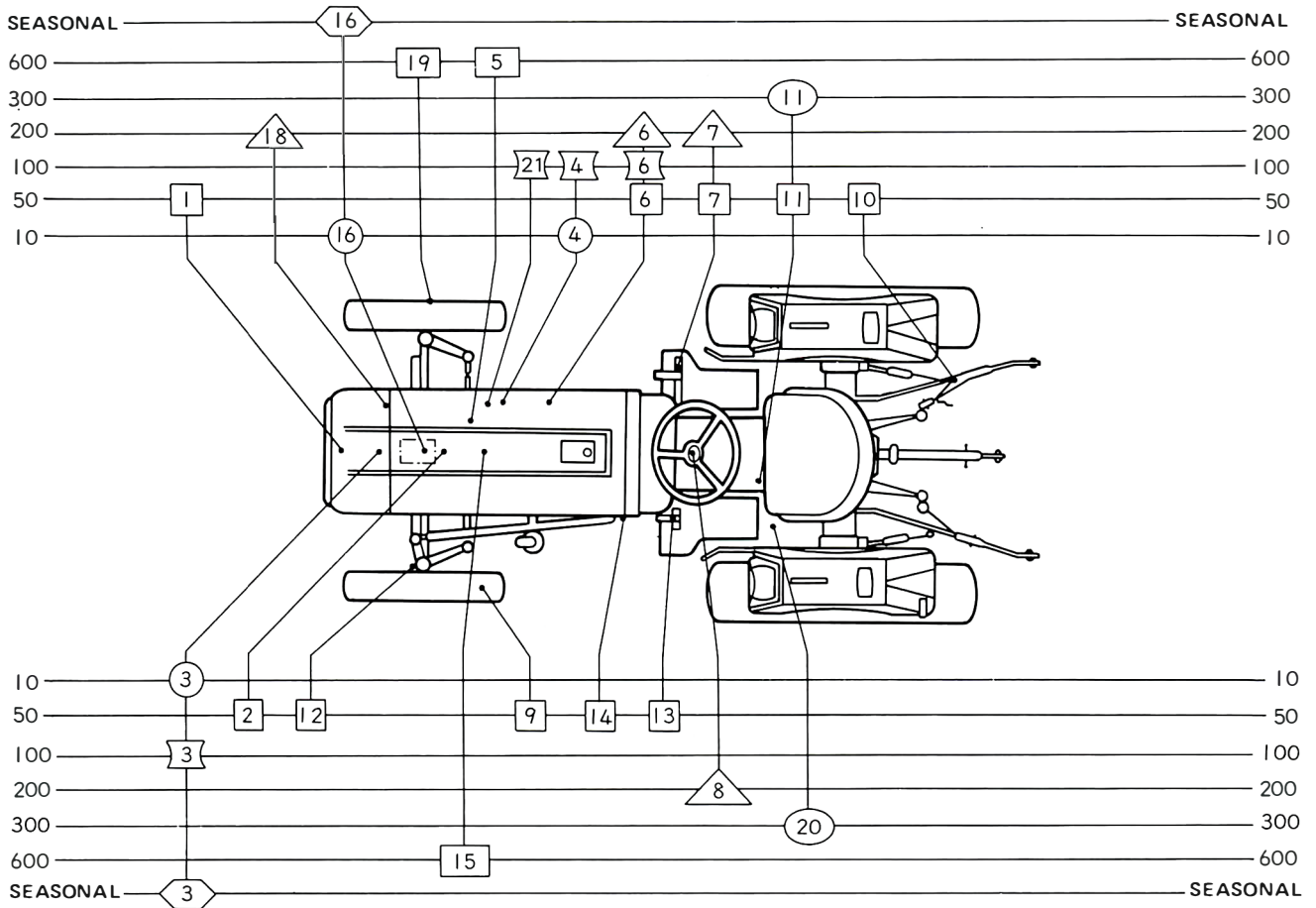

NO.	LUBRICATION AND MAINTENANCE ITEMS	CHECK	CLEAN	LUBE	CHANGE	ADJUST	SERVICE INTERVALS	NO.	LUBRICATION AND MAINTENANCE ITEMS	CHECK	CLEAN	LUBE	CHANGE	ADJUST	SERVICE INTERVALS	
4	Engine Oil Level	x					Every 10 Hours or Daily	18	Fan Belt	x					Every 200 Hours	
3	Air Cleaner	x						6	Fuel Filter Element				x	x		
16	Radiator Coolant	x						7	Brakes							x
20	Hydraulic Filter				x		First 50 Hours	8	Steering Free-play							
11	Transmission Oil Level	x					Every 50 Hours	11	Transmission Oil				x		Every 300 Hours	
9	Tires	x						20	Hydraulic Oil Filter				x			
13	Clutch Pedal					x			19	Front Wheel Bearings			x		Every 600 Hours	
1	Battery	x							5	Fuel Injectors	x					
6	Fuel Filter								15	Valve Clearance	x					
14	Lubrication Fittings: Steering Linkage			x					16	Radiator Coolant				x	Seasonal	
12	Front Wheel Spindles (2)			x					3	Air Cleaner Element				x		
2	Pivot Shaft (2)			x					21	Fuel Injection Pump Oil			x			
13	Clutch Pedal															
7	Brake Pedal															
10	Hydraulic Lift Linkage			x												
4	Engine Oil and Oil Filter				x		Every 100 Hours									
6	Fuel Filter		x													
3	Air Cleaner Element		x													

# LUBRICATION AND MAINTENANCE

## LUBRICATION AND MAINTENANCE CHART — FORD 1710 FOUR-WHEEL DRIVE

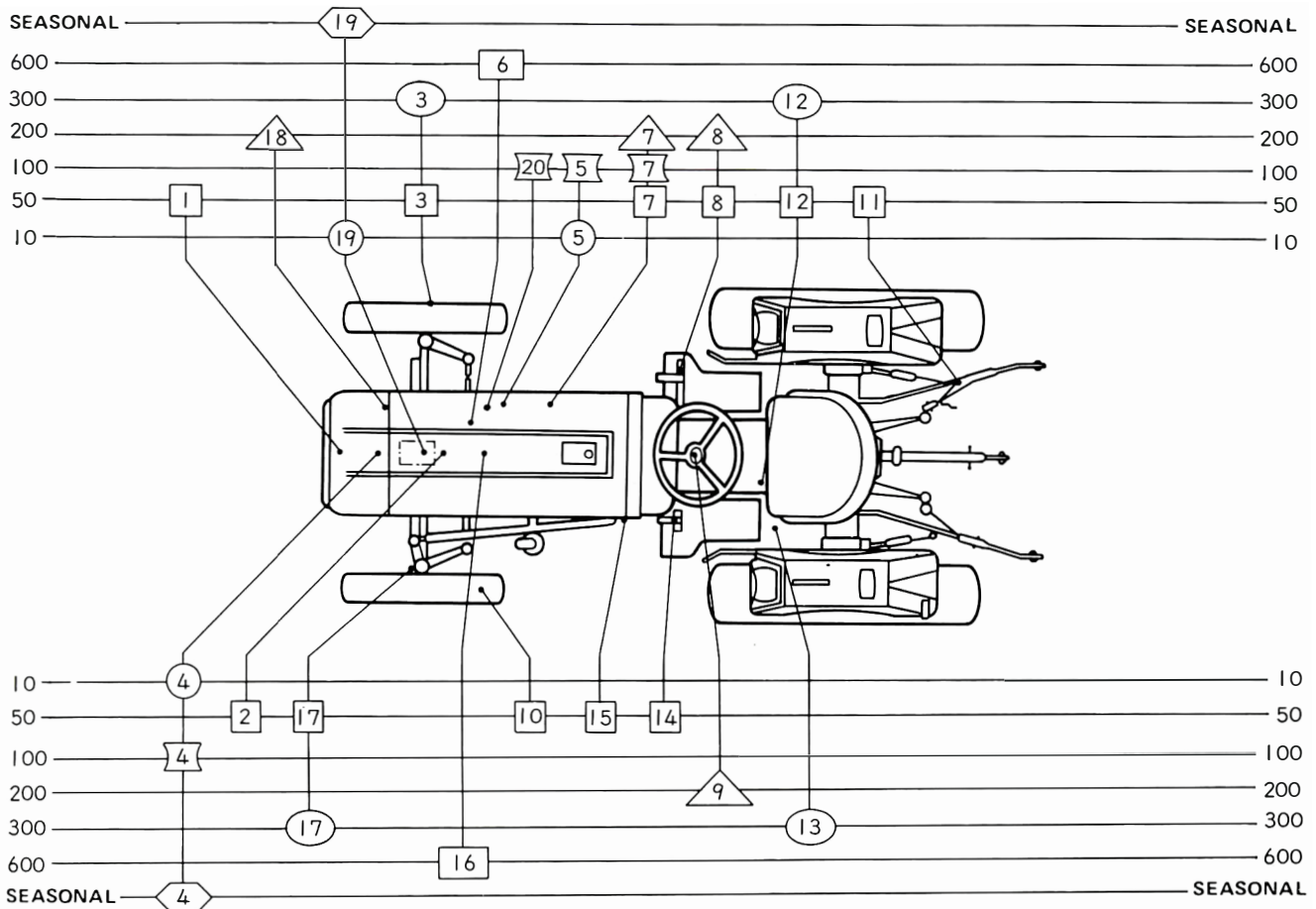

NO.	LUBRICATION AND MAINTENANCE ITEMS	CHECK	CLEAN	LUBE	CHANGE	ADJUST	SERVICE INTERVALS	NO.	LUBRICATION AND MAINTENANCE ITEMS	CHECK	CLEAN	LUBE	CHANGE	ADJUST	SERVICE INTERVALS
19	Radiator Coolant	x					Every 10 Hours or Daily	18	Fan Belt	x				x	Every 200 Hours
5	Engine Oil Level	x						8	Brake	x			x	x	
4	Air Cleaner	x						7	Fuel Filter Element				x		
13	Hydraulic Filter				x		First 50 Hours	9	Steering Free-play	x				x	
1	Battery	x					Every 50 Hours	3	Front Diff. Oil				x		Every 300 Hours
3	Front Diff. Oil Level	x						17	Front Axle Oil				x		
10	Tires	x						12	Transmission Oil				x		
12	Transmission Oil Level	x						13	Hydraulic Filter				x		
17	Front Axle Oil Level	x						6	Fuel Injectors	x				x	Every 600 Hours
7	Fuel Filter	D	R	A	I	N		16	Valve Clearance	x				x	
14	Clutch Pedal			x		x			19	Radiator Coolant				x	Seasonal
8	Brake Pedal			x				4	Air Cleaner Element				x		
11	Hydraulic Lift Linkage			x											
2	Pivot Shaft			x											
15	Steering Linkage			x											
5	Engine Oil and Oil Filter				x		Every 100 Hours	19	Radiator Coolant				x		Seasonal
7	Fuel Filter		x					4	Air Cleaner Element				x		
4	Air Cleaner Element		x												
20	Fuel Injection Pump Oil			x											

# LUBRICATION AND MAINTENANCE

## FUEL AND LUBRICANTS

### DIESEL FUEL

Type of fuel to use:

When operating in temperatures above 20° F (–6.7°C), use diesel fuel oil No. 2-D with a minimum cetane rating of 40. When operating in temperatures below 20° F (–6.7°C), use diesel fuel oil No. 1-D with a minimum cetane rating of 40. Low ambient temperatures as well as engine operation or high altitudes may require use of fuels with higher cetane ratings.

Fuel represents a major portion of your tractor operating costs; therefore, it is important to use it efficiently. Do not let low price tempt you to use inferior diesel fuel. The initial savings is a false economy when you consider the damage poor fuel can do to your tractor fuel system.



### FUEL USAGE SAFETY

Fuel is becoming very expensive and scarce. As a result, many of our customers are trying new fuels or blends to reduce costs and conserve energy.

Today's new fuels or blends are frequently more volatile and there is a need to handle them carefully. Furthermore, some of the blends are dangerous and should not be used at all.

The following new or blended fuels are becoming available or are sometimes recommended by certain sources. Our recommendations are as follows:

### Dieseloil

Under no circumstances should gasoline, alcohol or gasohol be added to diesel fuel. These combinations can create an increased fire hazard and under certain circumstances an explosive hazard. They are more dangerous (explosive) than pure gasoline in a closed container such as fuel tank. Do Not Use These Blends.

In addition, let's review the old recommendations. These are even more important today:

- Never remove the Fuel cap or refuel the tractor when the engine is running or is hot.
- Don't smoke while refueling or while anywhere near fuel.
- When filling the tank, maintain control of the nozzle.
- Don't fill the fuel tank to capacity...allow room for expansion.

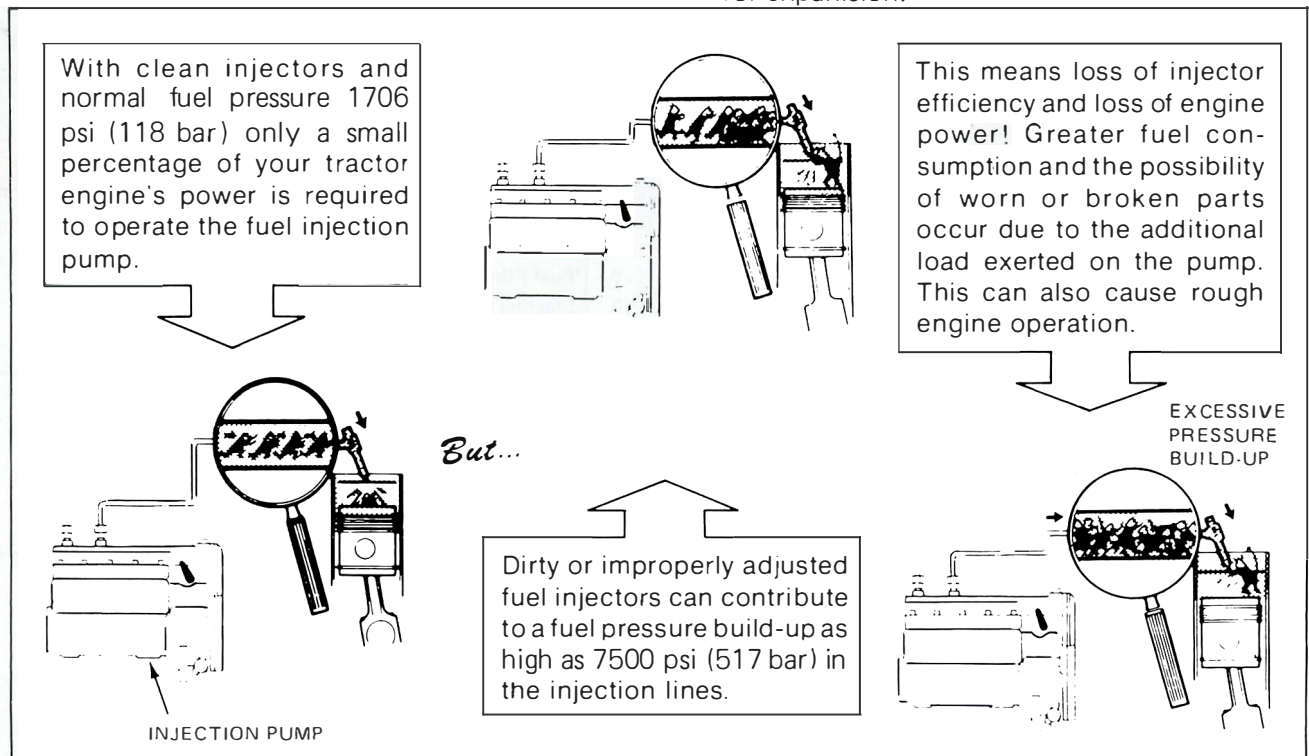
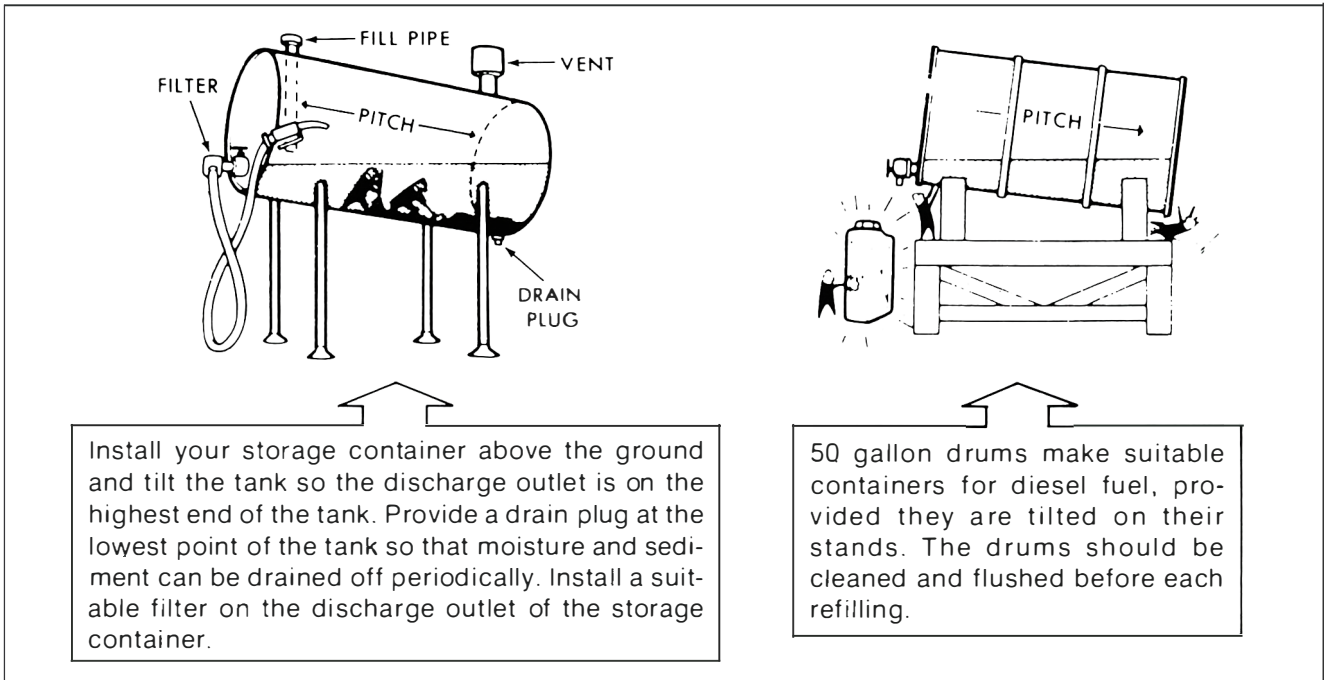

Figure 38 – Dirt vs. Injectors



**Figure 39 – Diesel Fuel Storage**

- Wipe up spills immediately.
- Always tighten the fuel tank cap securely.
- If the original equipment fuel tank cap is lost, always replace it with a Ford approved cap. A will-fit cap may not be safe.
- Keep equipment properly maintained.
- Keep equipment clean – free of trash and oil.
- Don't drive equipment near open fires.
- Never use gasoline for cleaning parts.

**NOTE:** Use only fuel designated for diesel engines. Some heating fuels contain harmful chemicals that, if used, can seriously affect tractor efficiency and performance. Refer to the "Engine Oil Recommendations" on Page 32 for additional fuel information.



**WARNING:** Fuel oil in the injection system is under high pressure and can penetrate the skin.

Unqualified persons should not remove or attempt to adjust a pump injector, nozzle or any part of the fuel injection system.

DO NOT use your hand check for leaks. Use a piece of cardboard or paper to search for leaks.

If any fluid is injected into the skin obtain medical attention immediate-

ly or gangrene may result.

Failure to follow these instructions can result in serious injury.

## FUEL STORAGE

Extremely small clearances exist between the fuel delivering elements of the fuel injection pump and the fuel delivering elements of the injectors. Therefore, it is of vital importance that precautions be taken to make sure the fuel is kept free of dirt and water, Figure 38.

Diesel fuel should be stored in black iron tanks or containers. Do not store diesel fuel in a galvanized tank, as the zinc coating will react with the fuel and form undesirable compounds that may interfere with the proper operation of the fuel injection pump and injectors.

The most satisfactory arrangement is a bulk storage installation, Figure 39 with either a tank and pump, or a gravity feed installation located high enough for the tractor tank to be filled direct. The tank should slope downward at the rear to allow sediment to settle away from the take-off point. Whenever the tank is refilled, allow the fuel to settle for 12 hours before using.

A drain valve should be positioned at the lowest point in the tank so the moisture and sediment can be drained periodically. A fuel outlet filter

# LUBRICATION AND MAINTENANCE

should be used, as shown in Figure 39. Use the largest tank feasible and keep it as full as possible to minimize condensation.

If bulk storage is not possible and the fuel is stored in barrels keep them in a clean, dry place. The barrel in use should be fitted with a fuel outlet filter and a drain tap, and should be supported so it slopes downward 1/2 inch per foot of length away from the tap.

After use, install the cap at the top of the barrel and clean up fuel which may have been spilled. Diesel fuel will not evaporate and thus will collect dust and dirt.

## REFUELING THE TRACTOR

If there is no filter on the outlet of the storage tank, filter the fuel through a 100-mesh screen or finer when filling the tractor fuel tank. Keep the tractor tank as full as possible to minimize condensation.

**NOTE:** It is a good practice to fill the tractor fuel tank with fuel at the end of each day, as this will reduce overnight condensation. Also, any fuel which may have been spilled should be cleaned up.

## LUBRICANTS

Type of lubricant to use;  
 Transmissin, Rear Axle, Final  
 Reduction, Hydraulic System  
 and Power Steering Oil . . . . . FORD 134  
 Engine Crankcase . . . . . FORD TRACTOR  
 SUPER PREMIUM  
 ENGINE OIL OR  
 API SF/CD QUALITY OIL

Front Wheel Bearings and All  
 Lubrication Fittings . . . . . ITM1C-137-A  
 OR NLG1 GRADE  
 2 EP GREASE  
 WITH LITHIUM  
 SOAP

**NOTE:** Ford Tractor engine oil is a super premium, heavy-duty engine oil compounded specifically to meet the rigid requirements of Ford Tractor engines. Ford engine oil exceeds both SF and CD requirements. It is available from your Ford Tractor-Equipment dealer. Use the following chart to determine which SAE Grade engine oil to use:

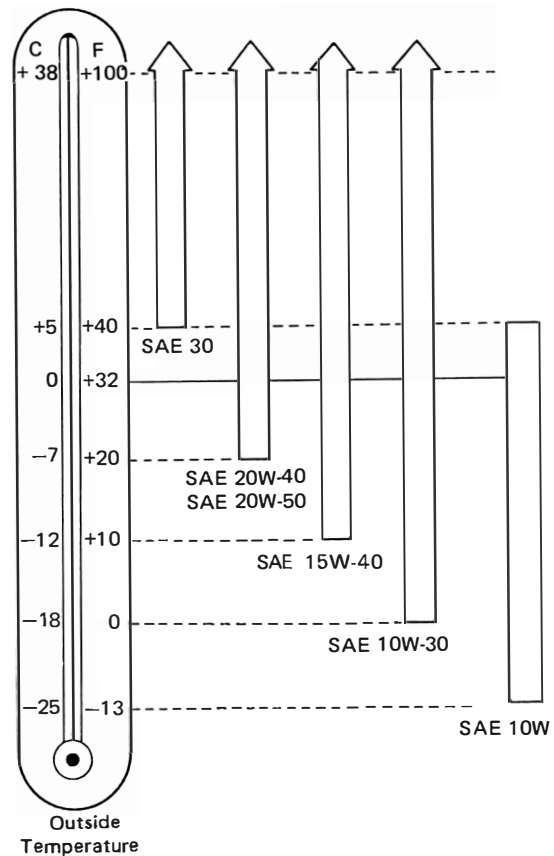

In areas where prolonged periods of extreme temperatures are encountered, local lubricant practices are acceptable, such as the use of SAE 5W in extremely cold temperatures or the use of SAE40 or SAE50 in extremely high temperatures.

## IMPORTANT;

Engine crankcase oil drain intervals should be adjusted downward when diesel fuel sulfur content is above 0.5%.

Consult your dealer for details of Engine Crankcase Oil usage.

## LUBRICANT STORAGE

Your Ford Tractor is equipped with lubricant filters to protect vital points from damage caused by dirt which may enter under normal operating conditions. Precautions must, however, be taken by you to prevent lubricant contamination by dirt or water during storage. Service intervals in this section are based on the assumption that only new oil, of the type specified, is used.

# LUBRICATION AND MAINTENANCE

Barrels of lubricant should be kept under cover, preferably in a clean, dry place, and should be clearly marked to indicate the lubricant which they contain.

When a barrel is kept in an exposed location, it should be tilted to allow any moisture to run away from the filler cap. Always use a clean container when transferring oil from a barrel to the tractor and make sure that any cap or bung, which has been removed, is installed as soon as possible.

## FUEL AND LUBRICANT SERVICE PROCEDURES

### ENGINE

**Checking Oil Level:** Check the engine oil level daily or every 10 hours.

1. With the tractor standing level, and after the engine has been stopped for a period of time, check the oil level with the dipstick, Figure 40.

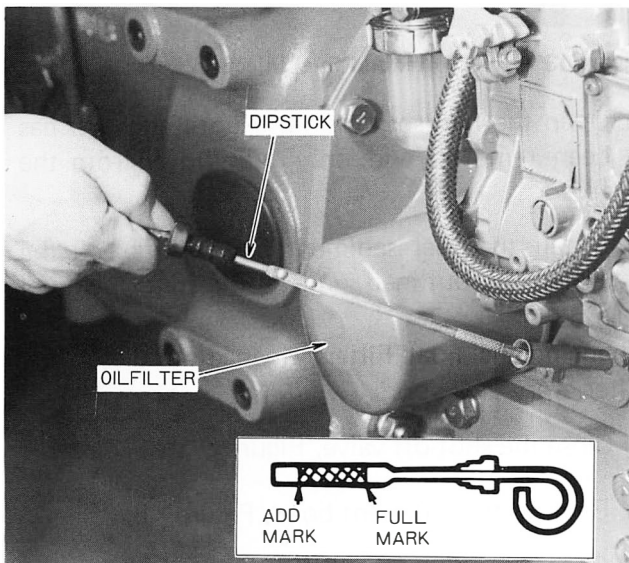

Figure 40 – Engine Oil Level Dipstick and Filter

2. If the oil level is low, remove the filler cap, Figure 41 and add oil to the engine through the filler hole to bring the oil level between the marks on the dipstick. Be careful not to overfill.
3. Install the oil filler cap.

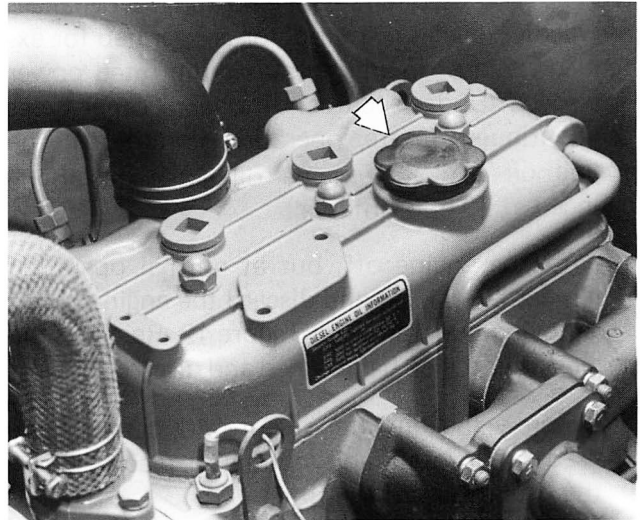

Figure 41 – Engine Oil Filler Cap

**Changing Oil and Filter:** Change the engine oil every 100 hours and the engine oil filter every 200 hours.

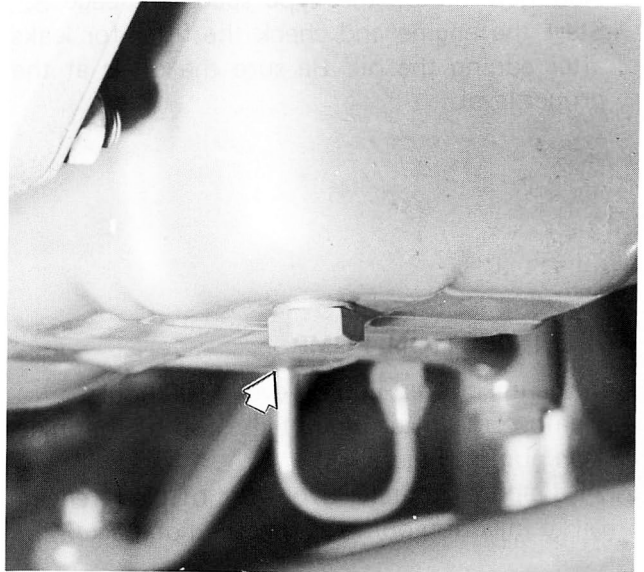

Figure 42 – Engine Oil Drain Plug

**NOTE:** Oil intervals should be adjusted according to sulfur-content of diesel fuel. The use of fuel with a sulfur content above 1.3% is not recommended.

Sulfur Content, %	Oil Change Interval
Below 0.5	Normal
0.5 – 1.0	1/2 Normal
Above 1.0	1/4 Normal

# LUBRICATION AND MAINTENANCE

**NOTE:** More frequent engine oil and filter changes are recommended if the tractor is operated for extended periods of time at maximum rated power and speed. Under such conditions, or other types of continued severe operating conditions, the engine oil and the engine oil filter should be changed at 70 hour intervals.

1. With the engine off, but at normal operating temperature, drain and discard the engine oil by removing the drain plug, Figure 42. Reinstall the plug after the oil has drained and discard the oil.
2. Unscrew the oil filter, Figure 40, catching the used oil in a suitable container placed below the filter. Discard the filter.
3. Coat the gasket on the new filter with a film of oil. Screw the filter into place until the gasket contacts its mating surface, then turn the filter approximately 3/4 of a turn by hand. Do not overtighten.
4. Add new oil of the type specified, page 32. Start the engine and check the filter for leaks after adding the oil. Be sure the oil is at the proper level.

## FUEL INJECTION PUMP

Add the injection pump oil every 100 hours.

1. Remove the filter plug at the top of the injection pump. (Figure 43)
2. Add approximately 5 ounces of clean engine oil to injection pump as specified on page 32.

**NOTE:** The Fuel Injection Pump utilizes oil from the Engine Crankcase for lubrication. To assure the Injection Pump oil is clean, add approximately 5 oz (150 cc) of clean engine oil to the Injection Pump when changing engine oil.

## FUEL FILTER

**Draining the Filter:** Drain the diesel fuel filter when water is visible in the sediment bowl.

**Cleaning the Fuel Filter:** Clean the fuel filter every 100 hours by rinsing in a container of clean diesel fuel.

1. Be sure there is adequate fuel in the fuel tank, close the fuel shut-off valve, Figure 6. then remove the fuel sediment bowl, Figure 43.

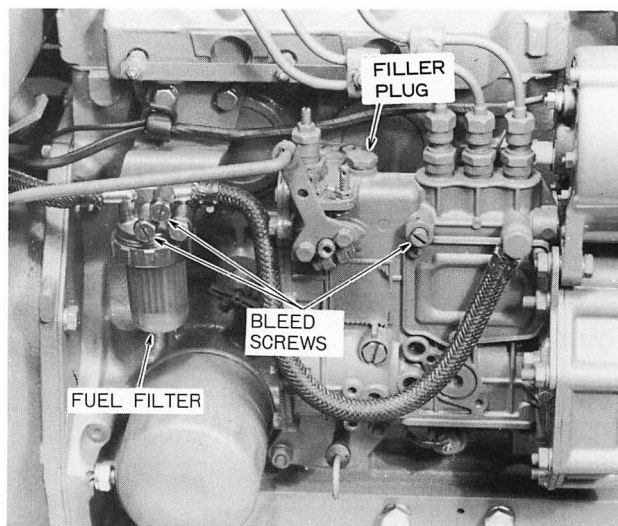

**Figure 43 — Fuel Filter and Fuel Injection Pump**

2. Open the fuel shut-off valve until all water has been removed and only fuel flows from the filter.
3. Install the fuel sediment bowl and bleed the system as outlined under "Bleeding the Fuel System."

**Changing the Fuel Filter:** Change the diesel fuel filter every 200 hours.

1. Close the shut-off valve, Figure 6,
2. Remove the sediment bowl, Figure 43.
3. Open the fuel shut-off valve to drain any remaining water from the tank.
4. Discard the old element and install a new element.
5. Install and securely tighten the sediment bowl.

6. Open the fuel shut-off valve so fuel will flow to the filter.
7. Bleed the fuel filter and injection pump as covered under "Bleeding the Fuel System."

### BLEEDING THE FUEL SYSTEM

Bleed the fuel system after it has been drained:

- If a new filter element has been installed,
- If the tractor has run out of fuel,
- If the lines leading to or from the filter have been disconnected,
- If the injection pump has been removed and reinstalled.

Bleed the fuel system as follows:



**WARNING:** Fuel oil in the injection system is under high pressure and can penetrate the skin.

Unqualified persons should not remove or attempt to adjust a pump injector, nozzle or any part of the fuel injection system.

DO NOT use your hand to check for leaks. Use a piece of cardboard or paper to search for leaks.

If any fluid is injected into the skin obtain medical attention immediately or gangrene may result.

Failure to follow these instructions can result in serious injury.

**Injector Lines:** Bleed the injector lines if the tractor has run out of fuel, if new injectors have been installed, or if the injection pump has been removed for service pairs.

1. Loosen the injector line fittings at the injectors.
2. Move the hand throttle control lever to its wide open position.
3. Crank the engine until air-free fuel flows from each connection, then tighten the fittings to 18-22 lbs. ft. (24-29 N.m)

**IMPORTANT:** Do not crank the engine continuously for more than 30 seconds. Doing so may cause starting motor failure. If air is not purged from the system, repeat the procedure.

1. Be sure there is adequate fuel in the fuel tank.
2. Open the fuel shut-off valve.
3. Open the bleed screws at the top of the fuel filter (Figure 43) and let the air bubbles escape from the screws. Then tighten bleed screws.
4. Open the bleed screw at the pump (Figure 43) and let the air bubbles escape, then close the bleed screw.
5. Push the hand throttle to the high speed position. Turn the engine over for a few seconds to bleed the high pressure fuel tube.

# LUBRICATION AND MAINTENANCE

## AIR CLEANER

**Checking Dirt Level:** Check the dirt level in the dust pan daily or every 10 hours (Figure 44).

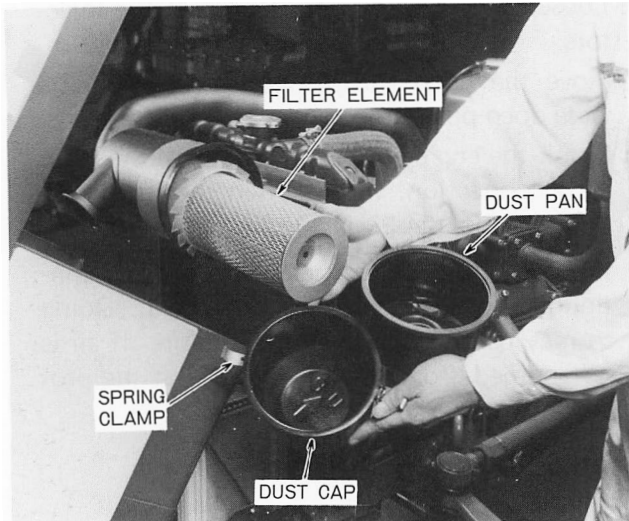

**Figure 44 – Air Cleaner – Disassembled**

Clean the element every 100 hours of service.

1. Loosen spring clamps and remove dust cap, Figure 44.
2. Remove seal and dust pan from dust cap and clean dust cap, seal and dust pan using a damp lint free cloth, Figure 44.
3. Remove wing nut holding filter element and remove filter element from body.
4. Pat sides of element with palm of hand to remove dust trapped in the pleats.

**IMPORTANT:** Tapping element against hard surface or with hard objects may dent or break element end cap seals.

5. Using low air pressure (not over 30 psi, 2.1 bar), blow out remaining dust from inside out opposite normal air flow through the element.

**IMPORTANT:** Be careful not to rupture the filter element. Maintain a reasonable distance between the air nozzle and the filter element when directing air up and down the clean air side of the element pleats.

6. Clean the fins and inside of the air cleaner body with a dry cloth.

7. Check with a light bulb inside the element for leaks in paper or bonding of paper to end plate. Replace element if any leaks are found.

8. Reassemble the air cleaner.

## WASHING ELEMENT

1. Washing may be necessary to remove soot or oil material.
2. Agitate the element in warm water containing a small amount of non sudsing type detergent.

**IMPORTANT:** Do not use water hotter than the hand can stand, as the element will be damaged. Never wash the element with fuel oil, gas or solvent. Do not oil the element.

3. Rinse the element with clean water. Shake excess water from the element and allow it to air dry.

**IMPORTANT:** Do not dry element with compressed air, as the air will rupture a wet element. Also, do not install a wet element as the tractor engine will not start with a wet element installed.

4. After drying, check for damage by holding a light bulb inside the element. If an even, fine pattern of light is seen, the element is clean and undamaged. A bright spot of light indicates the element is damaged, and a new element must be installed.  
Change the element after six cleanings or once a year.

## TRANSMISSION, REAR AXLE HYDRAULIC SYSTEM AND OPTIONAL POWER STEERING

**Checking Oil Level:** Check the oil level every 50 hours.

1. With the tractor standing level and the engine off, check the oil level with the dipstick, Figure 45.
2. The oil is at the correct level when the oil level is between the mark and the lower end of the dipstick. If low, add new oil of the type specified, page 32, through the combined dipstick/fill plug. Do not fill beyond the mark on the stick, as the transmission will be over-filled.
3. Install the filler plug and dipstick.

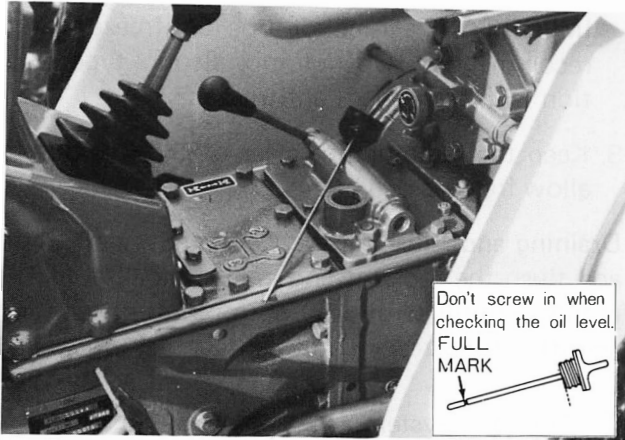
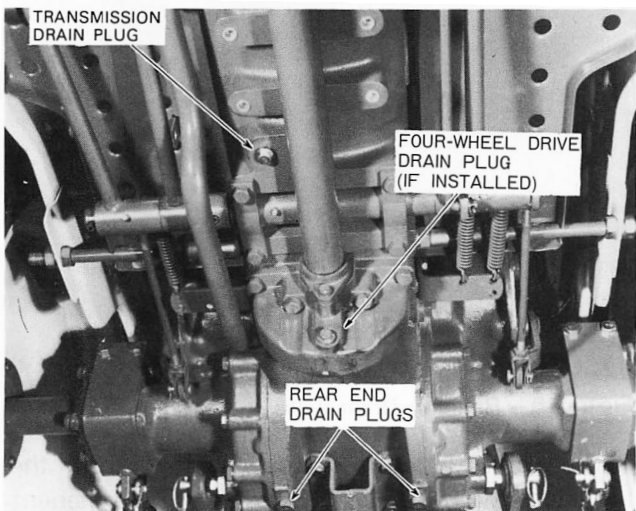

**Figure 45 – Transmission, Rear Axle and Hydraulic System Oil Level Dipstick and Fill Plug**

Changing Oil: Change the oil every 300 hours.

1. With the oil at normal operating temperature, drain the oil by removing the transmission and rear axle drain plugs, Figure 46. Reinstall the plugs after the oil has drained. Discard the oil.
2. Remove the filler plug, Figure 45, and fill with new oil of the type specified, page 32.
3. The transmission is filled to the correct level when the oil level is between the mark and the lower end of the dipstick. Do not fill beyond the mark on the stick, as the transmission will be overfilled.
4. Install the dipstick and dipstick/filler plug.

**IMPORTANT:** Because there is a common sump for the transmission, rear axle and hydraulic system, special attention is necessary in keeping the oil clean.



**Figure 46 – Transmission, Rear Axle Center Housing and Rear Axle Oil Drain Plugs**

## HYDRAULIC SYSTEM OIL FILTER

The hydraulic system is equipped with a spin-on type oil filter, Figure 47. Replace the filter after the first 50 hours of operation and every 300 hours thereafter following the procedure below.

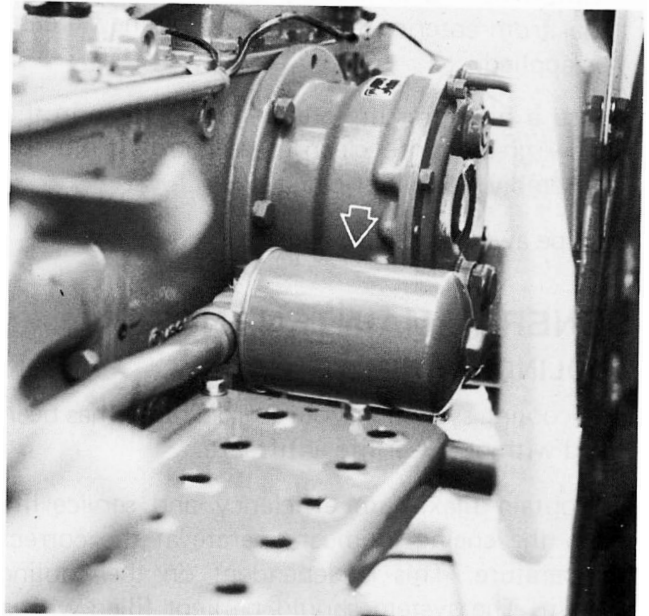

**Figure 47 – Hydraulic Oil Filter**

1. Unscrew the oil filter and discard.
2. Coat the gasket on the new filter with a film of oil. Screw the filter into place until the gasket contacts the sealing surface, then tighten the filter approximately 3/4 of a turn by hand. Do not over tighten.
3. Start the engine and check the hydraulic oil filter for leaks.
4. Stop the engine and check the hydraulic oil level. Replenish if necessary.

## LUBRICATION FITTINGS

The following lubrication points (refer to the Lubrication Chart, page 28 or 29) require the application of a good quality grease every 50 hours. In extremely dirty conditions, lubrication should be more often. Refer to page 32 for the type of grease that should be used.

- Steering linkage
- Pivot shaft
- Front wheel spindles

# LUBRICATION AND MAINTENANCE

- Pedal shaft
  - 3-point linkage
  - Front-wheel drive king pins (if so equipped)
1. Wipe away all old grease and dirt from the lubrication fittings to prevent dirt or foreign material from entering the fittings when new grease is applied.
  2. Use a high pressure grease gun to force in the new grease until clean grease oozes from the assembly being lubricated.
  3. Wipe away any excess grease.

## GENERAL MAINTENANCE COOLING SYSTEM

The cooling system in your Ford Tractor has been filled with one year life antifreeze.

To obtain maximum efficiency and service life from the engine, it must operate at the correct temperature. This is dependent on the cooling system. The system should be kept filled with a 50/50 solution of permanent antifreeze and clear water.

**Checking Coolant Level:** Check the coolant level daily or every 10 hours. This check should be made when the engine is cold.

1. Remove the radiator cap and visually check the level of the coolant.



**WARNING:** The cooling system operates under pressure which is controlled by the radiator cap. It is dangerous to remove the cap while the system is hot. Always cover the cap with a thick cloth and turn the cap slowly counterclockwise to the first stop. Allow all pressure to escape before removing the cap completely.

2. If the coolant level is more than 1-1/2 to 2 inches (3.8 to 5 cm) below the bottom of the filler neck, add clean water or antifreeze solution as necessary. If the cooling system already contains antifreeze, add only antifreeze solution of the correct water/antifreeze mixture. Plain water will dilute the solution and weaken its protection.

**IMPORTANT:** Alcohol-type antifreeze is not recommended. Do not mix alcohol-type solution with permanent antifreeze.

3. Keep the radiator fins clear of chaff or dirt to allow free passage of air.

**Draining and Flushing the Cooling System:** Drain and flush the radiator and engine block every 12 months. Refill with a 50/50 mixture of long life (Ford) antifreeze, or equivalent, and clear water.

To Drain the System:

1. Remove the radiator cap and open the drain valve at both the radiator and the engine block. The radiator drain valve is located on the bottom right side of the radiator, Figure 48. The engine block drain valve is located on the right side of the engine. See Figure 49.
2. After the coolant has drained, place a water hose in the radiator filler neck and run water through the system with the engine running. Make sure water is flowing from the block drain valve before starting the engine. When the water flowing from the drain valve is free of discoloration and sediment, stop the engine and remove the hose. Allow all water to drain from the system through drain valves.



**Figure 48 – Radiator Drain Valve**

3. Close the two drain valves and slowly refill the system with a 50/50 solution of permanent antifreeze and clear water. Fill until the coolant level is approximately 1-1/2 to 2 inches (3.8 to

## LUBRICATION AND MAINTENANCE

5 cm) below the bottom of the filler neck. Do not fill beyond this level.

**IMPORTANT:** Bleed coolant system to make sure that no air pockets remain.

4. Clean the radiator cap and cap seal. Install the cap.
5. Clean the radiator front screen Figure 50.

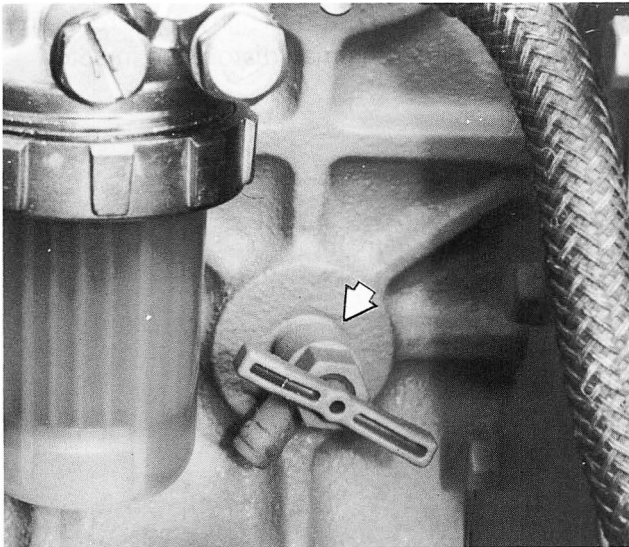

Figure 49 – Engine Block Drain Valve

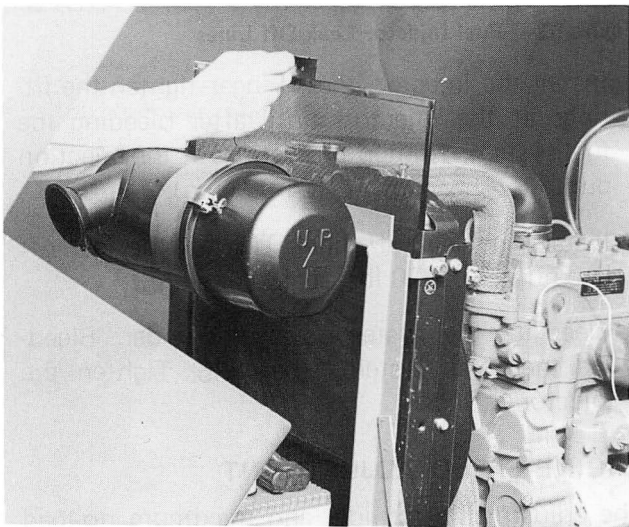

Figure 50 – Radiator Screen

6. Run the engine until normal operating temperature is reached, then stop the engine and recheck the coolant level. Add coolant as required.

**IMPORTANT:** Never run the engine when the cooling system is empty, and do not add cold water or cold antifreeze solution if the engine is hot.

**Thermostat:** The thermostat is located in the coolant outlet connection in the front of the cylinder head (Figure 51).

When the engine is cold, the thermostat, which is a heat sensitive valve, shuts off the flow of coolant to the radiator, thus allowing rapid engine warm up. A recirculating bypass allows the coolant to circulate within the engine whenever the thermostat shuts off flow to the radiator.

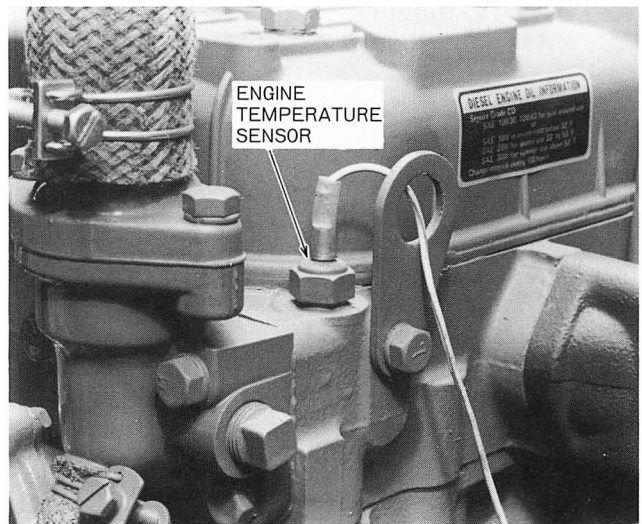

Figure 51 – Thermostat Housing

**IMPORTANT:** Do not remove the thermostat in an attempt to improve the cooling. This will cause the engine to run below normal working temperatures, resulting in excessive engine wear.

If it ever becomes necessary to install a new thermostat, it should be positioned in the recess of the water outlet connection so that the heat element (spring end) will be in the cylinder head of the engine.

**Fan Belt:** A belt-driven fan at the front of the engine draws air through the fins of the radiator to cool the coolant in the radiator. A slipping fan belt will lower the efficiency of the fan, resulting in the engine running too hot. If the belt is too tight, it will shorten the alternator bearing life. A correctly tightened belt will deflect 7/16 to 9/16 inch (10 to 15 mm) when 20 to 25 pounds (9 to 11 kg) thumb pressure is applied midway between the belt pulleys. Check the condition and tension of the fan belt every 200 hours. If the belt shows signs of cracking or fraying, install a new belt.

# LUBRICATION AND MAINTENANCE

To Adjust Belt Tension:

1. Loosen the alternator mounting bolts, Figure 52.
2. Pry the alternator away from the engine and tighten the mounting bolts.
3. Recheck belt deflection.



**WARNING:** Never attempt to loosen or tighten the bolts when the engine is running.

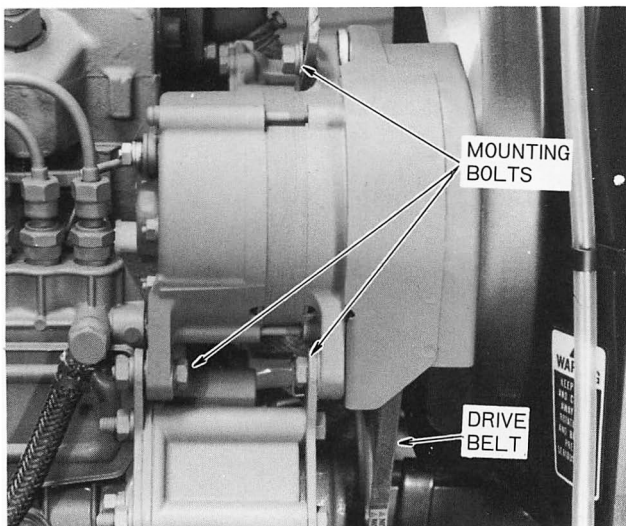

Figure 52 – Alternator Mounting Bolts

## FUEL INJECTOR REMOVAL AND INSTALLATION

The injectors should be cleaned, tested, and adjusted every 600 hours. Do not disassemble or adjust the injectors yourself. Remove them from the tractor engine and have them serviced by your Ford Tractor-Equipment Dealer.

To remove the injectors:

1. Clean all loose dirt from around the injectors and lines. Disconnect the leak-off lines from the injectors, Figure 53.
2. Disconnect the injection pump lines at the pump and injectors. Cover the ends of the lines and the injector inlet and leak-off ports to prevent the entry of dirt.
3. Remove the injectors.
4. Remove and discard the copper injector sealing washers from the injector locating bores. If a spare set of injectors is not im-

mediately available, cover the bores to prevent the entry of dirt.

After the injectors have been serviced, install them as follows:

1. Install a new copper sealing washer in each injector locating bore. Install the injectors and tighten the retaining nut to 43-51 lbs. ft. (58-69 N.m).

**IMPORTANT:** Do not overtighten the retaining nuts. Overtightening may distort the injector.

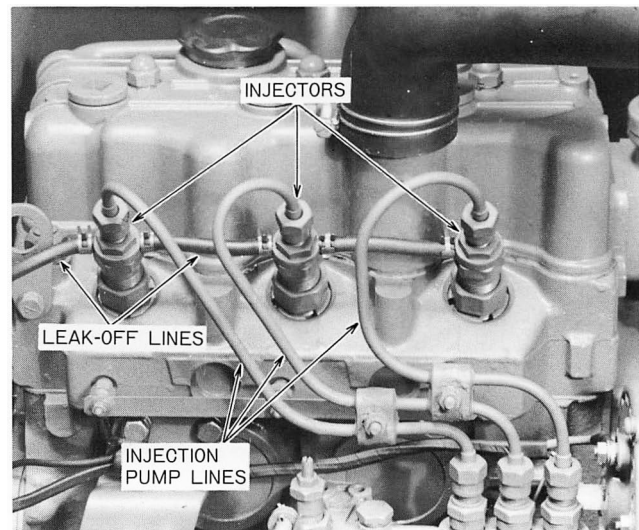

Figure 53 – Fuel Injector Leak-Off Lines

2. Install the injector lines. Finger tighten the fittings at the injectors until after bleeding the fuel system. Tighten the fittings at the injection pump to 18-22 lbs. ft. (24-30 N.m).
3. Install the leak-off line. Tighten the leak-off line nuts to 22-30 lbs. ft. (30-41 N.m).
4. Bleed the fuel system as covered under "Bleeding the Fuel System," page 35. Tighten the injector fittings.

## ENGINE SPEED ADJUSTMENT

The adjustments for idle and maximum no-load speed settings should be adjusted according to the following procedures:

1. Loosen the lock nuts, Figure 54.
2. Keep the foot throttle pedal at the same level as the upper surface of step plate.
3. Set the maximum no-load speed to 2800-2850 rpm, using the turnbuckle.

## LUBRICATION AND MAINTENANCE

4. Retighten the lock nuts.

**IMPORTANT:** Do not depress the foot throttle pedal below the level of the upper surface of the foot step plate.

5. Move the throttle lever forward until a resistance is felt. This is the idle position.

6. Loosen the bolts at the resistance spring.

7. Set the idle speed to 700-800 rpm, Retighten the bolts.

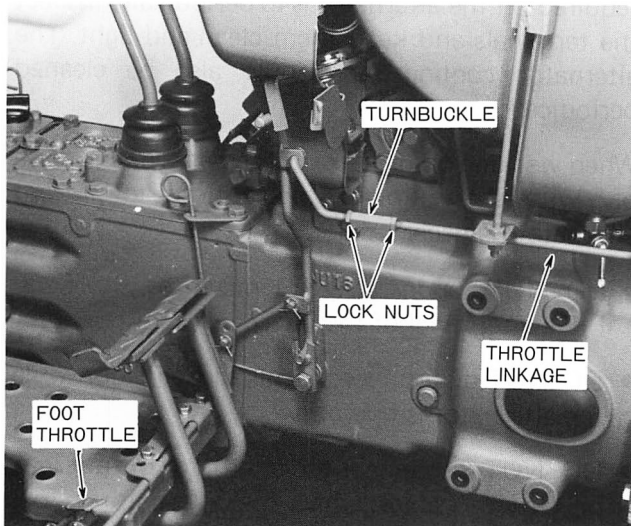

Figure 54 – Throttle Adjustment

### VALVE CLEARANCE (LASH)

Correct Valve clearance is one of the most important factors of good engine performance. Excessive clearance will cause the engine to operate excessively noisy, and insufficient clearance will cause poor performance. Because of this, it is extremely important that care be used when adjusting valve clearance.

**Checking and Adjusting Valve Clearance:** Check and adjust the valves every 600 hours. The clearance check and adjustment should be made with the engine cold.

1. Remove the valve rocker arm cover.
2. With the engine idling, check the clearance of each valve with a feeler gauge, Figure 55.

The setting should be:

Intake	.008 (.2 mm)
Exhaust	.008 (.2 mm)

3. If the clearance is incorrect on any valve, turn the adjusting screw at the push rod end of the valve rocker arm either into or out of the arm while checking for correct clearance with the feeler gauge.

4. Install the rocker arm cover. Use a new gasket if the old one is damaged. Tighten the cover bolts evenly.

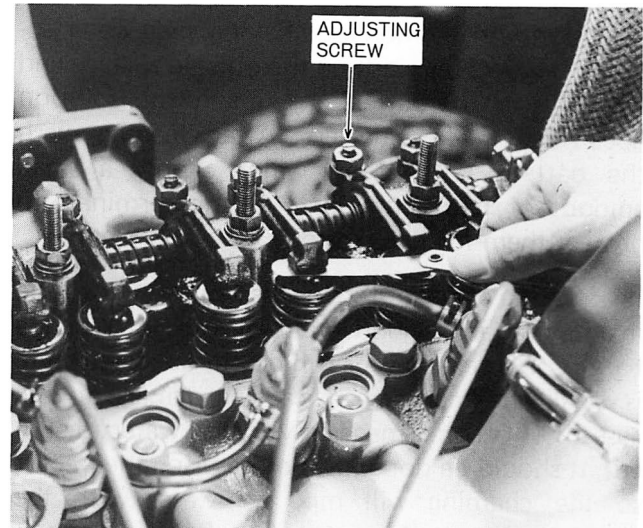

Figure 55 – Checking Valve Clearance

### MAINTENANCE AND INSPECTION OF THE ROPS

After the first 20 hours of operation and after every 500 hours of operation or six months, whichever comes first, do the following:

1. Check the torque of the ROPS mounting bolts. If necessary, tighten the bolts to the correct torque. See bolt torques' page 54.
2. Check the operator's seat and the mounting parts for the seat belt. Tighten the bolts to the correct torque. Replace parts that show wear or damage.

### POSSIBLE DAMAGE TO THE ROPS

If the machine has rolled over or the ROPS has been in some other type of accident (such as hitting an overhead object during transport) you must replace the ROPS to get the original protection.

After an accident, check for damage to (1) the ROPS, (2) the operator's seat, (3) the seat belt

# LUBRICATION AND MAINTENANCE

and the seat belt mountings. Before you operate the machine, replace all damaged parts.

**IMPORTANT:** Do not try to weld or straighten the ROPS.

## BATTERY

Keep the battery connections tight and free of corrosion. An ammonia or baking soda-water solution is good for washing the outside surface and terminals of the battery. Make sure the solution does not enter the battery. After cleaning, wash the battery with clean water. Apply a small amount of petroleum jelly to the terminals to protect them from corrosion.

In freezing temperatures, the battery must be maintained in a good state of charge. When a battery is discharged or run down, the electrolyte is weak and may freeze, causing damage to the case. If it becomes necessary to add water (distilled), it should be done just before using the tractor so the charging will mix the water with the electrolyte and prevent the water from freezing.

Determine the battery charge by checking the specific gravity of the electrolyte.

**Checking Electrolyte Level:** Check the electrolyte level in the battery every 50 hours.



**WARNING:** When the alternator is charging, an explosive gas is produced inside the battery. Therefore, always check the electrolyte level with the engine stopped. Do not use an exposed flame and do not smoke when checking the battery electrolyte level.

1. Clean the top of the battery, then remove the vent plugs.
2. If the electrolyte level is low, add distilled water. The level is correct when the liquid is 1/4 inch (6.35 mm) above the plates.

**NOTE:** Keep distilled water in a clean, well-covered, non-metallic container.

3. Install the vent plug after making sure the vent holes are not blocked. At below freezing temp-

eratures, be sure to run the engine for a period of time, after adding water, so the battery will charge and prevent the water from freezing.

## ALTERNATOR

The alternator, Figure 56, is belt-driven from the engine crankshaft pulley. It is important that belt slippage does not occur, otherwise, the charging rate will be affected. Details of belt adjustment are given on page 40.

Other than belt adjustment, the only maintenance required on the alternator is to periodically inspect the terminals and keep them clean and tight. The alternator cooling fan should also be cleaned periodically.

When working on or checking the alternator, comply with the following precautions to prevent alternator damage.

- DO NOT, under any circumstances, short the FIELD terminal of the alternator to ground.
- DO NOT disconnect the voltage regulator while the alternator is operating.
- DO NOT disconnect the alternator output lead or battery cables while the alternator is operating.

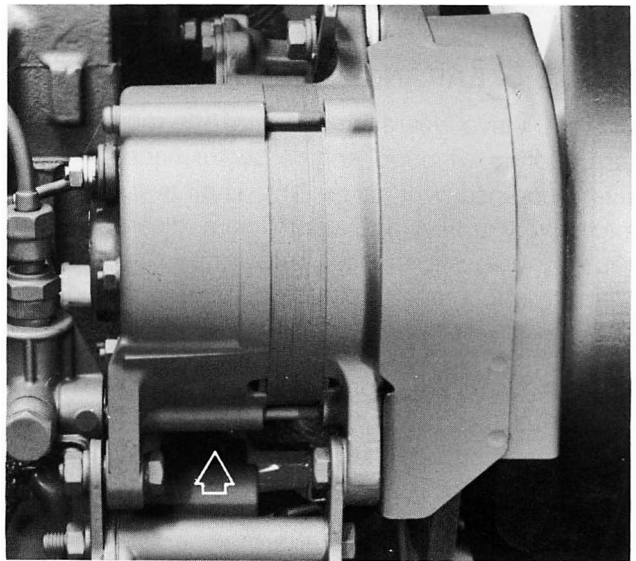

**Figure 56 – Alternator**

- DO NOT remove the alternator from the tractor without first disconnecting the negative (–) battery cable. If the battery is to be removed, disconnect the negative cable first.

## LUBRICATION AND MAINTENANCE

- If a battery is being installed, MAKE CERTAIN that the positive (+) cable is connected first and that the negative terminal is connected to ground. Reverse polarity will destroy the rectifier diodes in the alternator.

### VOLTAGE REGULATOR

The voltage regulator automatically controls the alternator charging rate. No attempt should be made to adjust the setting of the regulator.

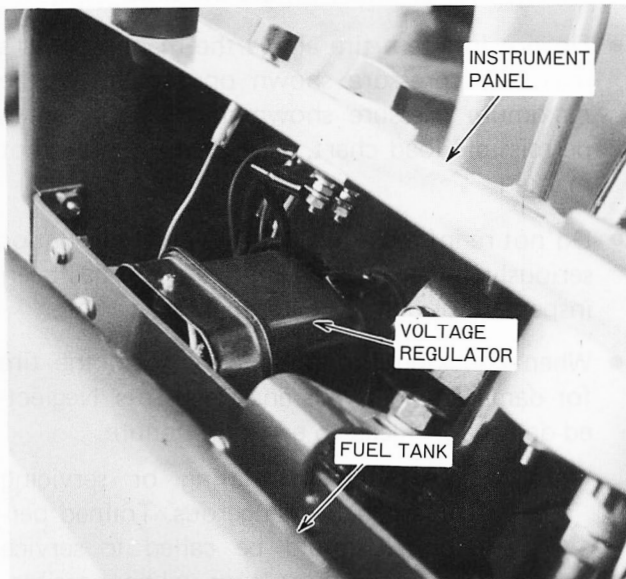

Figure 57 – Voltage Regulator

If the charge indicator warning light indicates that the alternator is not charging the battery, check the fan belt and the wiring connections. If these are satisfactory and the warning light continues to indicate no charge, consult your Ford Tractor Equipment Dealer.

### FUSE BOX

The fuse box is shown in Figure 58. Remove the fuse box cover by removing two screws and metal cover. The plastic fuse cover is easily removed by pulling it off. A spare 5 AMP and 15 AMP fuse are stored in the box. Always replace blown fuses with the specified fuse.

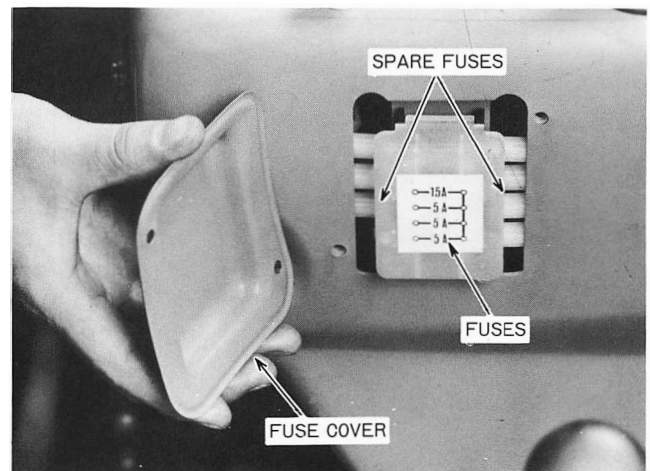

Figure 58 – Fuse Box

### HEADLAMP

Should a headlamp failure occur, the bulb must be replaced. To change the bulb;

1. Remove four screws securing the headlamp cover to fender, Figure 59.
2. Turn the socket to align the index tab and remove the socket from the housing, Figure 60.
3. Remove the bulb.
4. Install new bulb in the socket and install the socket with bulb in the housing.

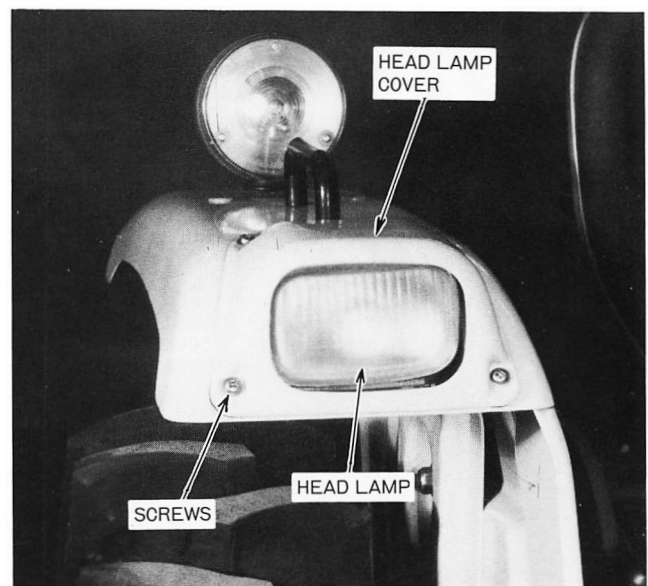

Figure 59 – Headlamp Assembly

# LUBRICATION AND MAINTENANCE

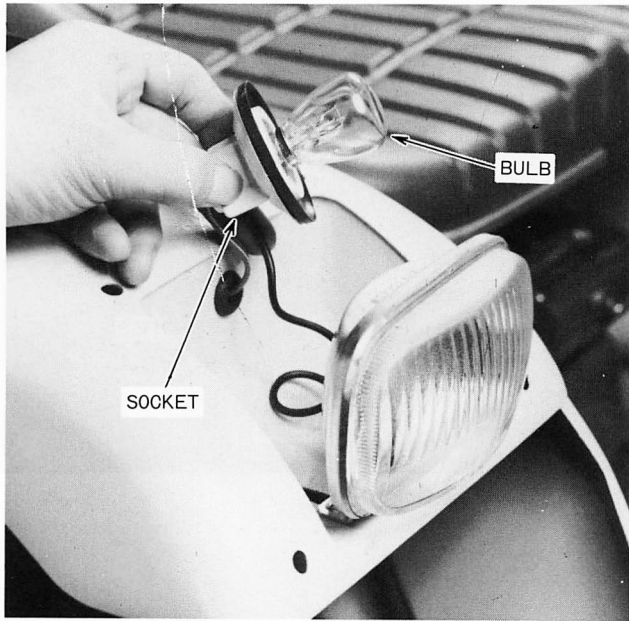

Figure 60 – Headlamp Socket

## TAIL LAMP AND FLASHER WARNING LAMP

To replace a tail lamp bulb or flasher warning lamp bulb:

1. Remove the lens, then remove the bulb.
2. Install a new bulb and reinstall the lens/and or rim assembly.

## INSTRUMENT LIGHTS

To change an instrument bulb:

1. Pull out the light socket from the Proof-Meter, Figure 61.

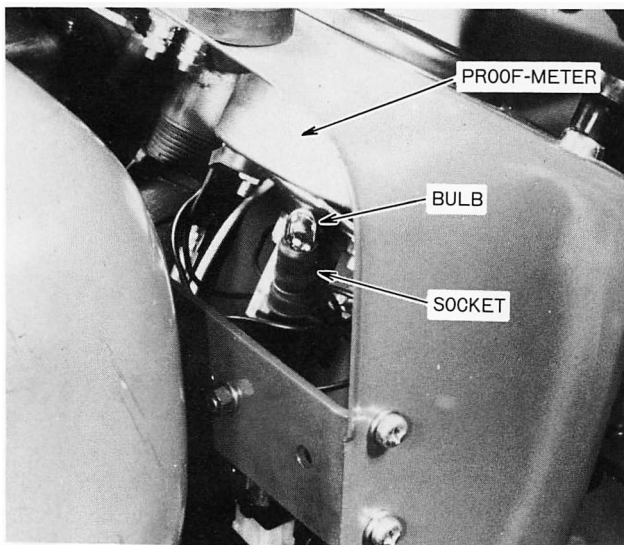

Figure 61 – Instrument Panel Lights

2. Replace bulb.
3. Position the light socket to the Proof-Meter.

## TIRES

### Inflation and Service

- Upon receiving your tractor, check the air pressure in the tires as indicated in the tables.
- Check tire pressure every 50 hours, or weekly.
- Tire inflation pressure affects the amount of weight which a tire may carry. Locate the tires for your tractor in the "TIRE INFLATION vs. PERMISSIBLE LOAD" chart on page 27. Do not over-or-under inflate the tires.
- Do not inflate a tire above the manufacturer's maximum pressure shown on the tire or the maximum pressure shown in the inflation vs permissible load chart, page 27 if the tire is not marked.
- Do not re-inflate a tire that has been run flat or seriously under-inflated until the tire has been inspected for damage by a qualified person.
- When checking tire pressure, inspect the tire for damaged side walls and tread cuts. Neglected damage will lead to early tire failure.



**WARNING:** Inflating or servicing tires can be dangerous. Trained personnel should be called to service and/or mount tires when possible. In any event to avoid possible serious or fatal injury, follow the safety precautions below:

- Be sure the rim is clean and free of rust.
- Lubricate both tire beads and rim flanges with soap solution. Do not use oil or grease.
- Use a clip-on tire chuck with a remote hose and gauge which allows the operator to stand clear of the tire while inflating it.
- NEVER INFLATE TO OVER 35 psi (2.4 bar) TO SEAT BEADS. If beads have not seated by time pressure reaches 35 psi, deflate the assembly, reposition tire on rim, relubricate both tire beads and rim flanges and re-inflate. Inflation beyond 35 psi with unseated beads may break the bead or rim with explosive force sufficient to cause serious injury.

## LUBRICATION AND MAINTENANCE

- After seating the beads, adjust inflation pressure to recommended operating pressure.
- Do not inflate a tire unless the rim is mounted on the tractor or is secured so that it will not move if the tire or rim should suddenly fail.
- Do not weld, braze, otherwise repair, or use a damaged rim.
- Never attempt tire repairs on a public road or highway.
- Use jack stands or other suitable blocking to support the tractor while repairing tires.
- Insure jack has adequate capacity to lift your tractor.
- Insure jack is placed on a firm level surface.
- Do not put any part of your body under the tractor or start the engine while the tractor is on the jack.
- Torque lug nuts to specification after reinstalling wheel. Check lug nut torque daily until torque stabilizes.
- Refer to tractor weighting section before adding ballast to the tires.

### FRONT WHEEL BEARINGS (TWO-WHEEL DRIVE)

The front wheels are carried on the wheel spindles by inner and outer tapered roller bearings. A grease retainer is provided at the inner end of the spindle, and a cover at the outer end, to retain the lubricant and to keep out dirt and other foreign material.

Front wheel bearings should be repacked every 600 hours as follows:

1. Apply the parking brake to hold the tractor securely.
2. Jack up one of the front wheels, remove the wheel and remove the cover, the cotter pin, and the nut, Figure 62. Remove the thrust washer, outer bearing, and then the hub.
3. Remove the grease retainer and the inner bearing from the inner end of the hub.

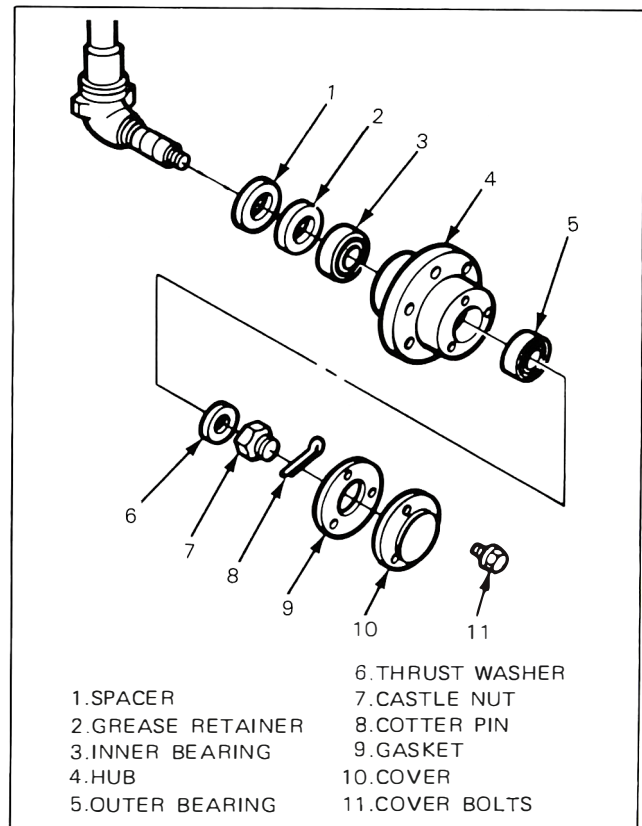

**Figure 62 — Servicing Front Wheel Bearings — Two-Wheel Drive**

4. Thoroughly clean all parts in a suitable solvent and allow to dry naturally. Do not use compressed air. Inspect the bearing cone and roller assemblies for excessive discoloration or wear of the rollers; similarly, check the bearing cups.
5. Repack the cone and roller assembly with clean grease (See specifications.) Pack approximately 1/4-inch (6.35 mm) of grease in the space between the bearing cups in the hub, but do not pack the hub completely. Apply a film of grease on the surface of the spindle.
6. Reinstall the inner bearing and install the grease retainer in the rear of the hub.
7. Place the wheel assembly on the spindle and install the outer bearing, thrust washer, and castellated nut. Tighten the nut, at the same time turning the wheel, until a slight drag is felt. Back off the nut until nearest slot in the nut lines up with the hole in the spindle. Install a new cotter pin, then the cover, with a new gasket.

# LUBRICATION AND MAINTENANCE

## STEERING WHEEL FREE PLAY ADJUSTMENT

Steering wheel play in the direction of rotation should be between .78-1.38 in. (20-35 mm) as shown in Figure 63. If the play exceeds, 2 in. (50 mm), then adjustment is necessary.

1. Make sure that all link bolts are tightened properly. If severe wear is apparent, install new parts.
2. Loosen the adjuster locknut on the right side of the steering gear box and turn the adjuster screw, see Figure 64. Turning the screw clockwise will decrease the free play while turning the adjuster screw counterclockwise will increase the steering wheel free play.

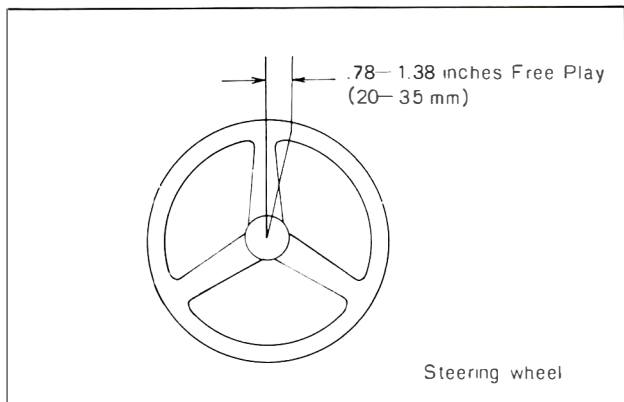

Figure 63 – Steering Wheel Free Play

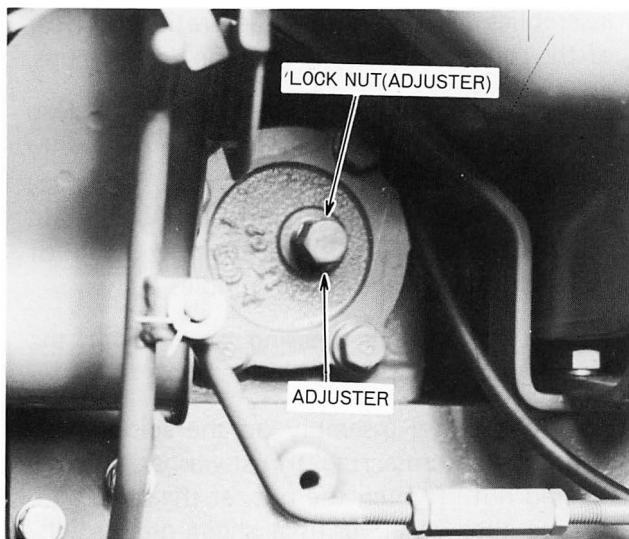

Figure 64 – Steering Wheel Free Play Adjustment

3. Once the adjustment is made, tighten the adjuster locknut securely.

## FRONT WHEEL TOE-IN

Front wheel toe-in adjustments on your tractor were made at the factory. Normally, the wheels maintain their toe-in; however, an occasional check should be made.

### Checking Toe-In

1. With the front wheels in the straight-ahead position, mark the front of the wheels (not the tires) at wheel hub height (Figure 65). Determine the straight-ahead position by turning the steering wheel from lock to lock and then halfway back.
2. Measure and record the distance between the front of the wheels at the marks, then push the tractor forward or backward until marks are at wheel hub height on the rear of the wheel.
3. Measure and record the distance between the marks at the rear of the wheels.
4. The difference between the dimensions recorded in Step 2 and 3 should give zero to 13/64-inch (0-5 mm) toe-in. The distance between the marks on the wheels should be zero to 13/64-inch (0-5 mm) greater when the marks are at the rear than at the front.
5. If the toe-in is not correct, adjust as outlined in the following procedure.

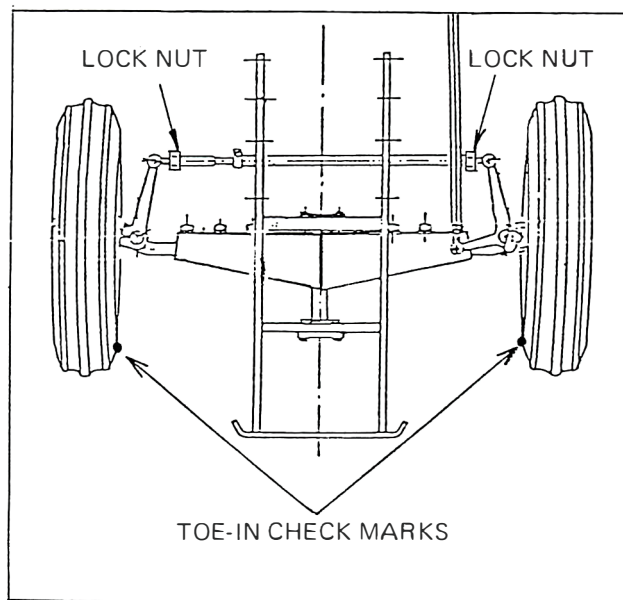

Figure 65 – Checking Toe-In

# LUBRICATION AND MAINTENANCE

## Adjusting Toe-In

1. Loosen the tie rod lock nuts.
2. Adjust the tie rod tube assembly as required to give zero to 13/64-inch (0-5 mm) toe-in.
3. After the correct toe-in is obtained, tighten the tie rod lock nuts.

## BRAKE ADJUSTMENT

Whenever the brake pedal travel becomes excessive, or if the travel of one pedal is unequal to that of the other, adjustment of each pedal should be made in the following manner:

1. Jack the tractor up until both rear wheels are free to turn. Support with safety stands.
2. Loosen the lock-nut, Figure 66, and rotate the brake rod as necessary until there is 3/4-1-3/16 inch (19-30 mm) of pedal free play. Lengthening the rod increases free play while shortening the rod decreases free play.
3. Test drive the tractor to make sure the braking action of both rear wheels is equal. Readjust as necessary.

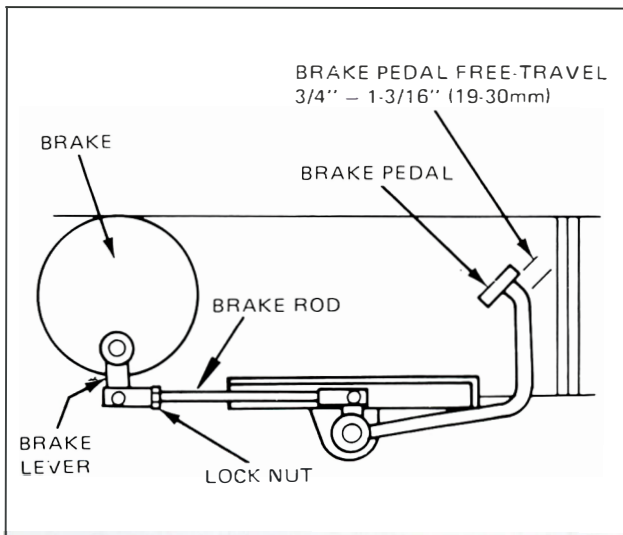

Figure 66 – Brake Pedal Adjustment.

## CLUTCH PEDAL ADJUSTMENT

To obtain maximum clutch life, it is essential that

the clutch pedal free travel be checked every 50 hours so as to maintain free travel at 3/4 – 1-3/16 inches (19-30 mm), Figure 67.

1. Remove the cotter pin and clevis pin.
2. Turn the clevis to increase or decrease pedal travel as required.

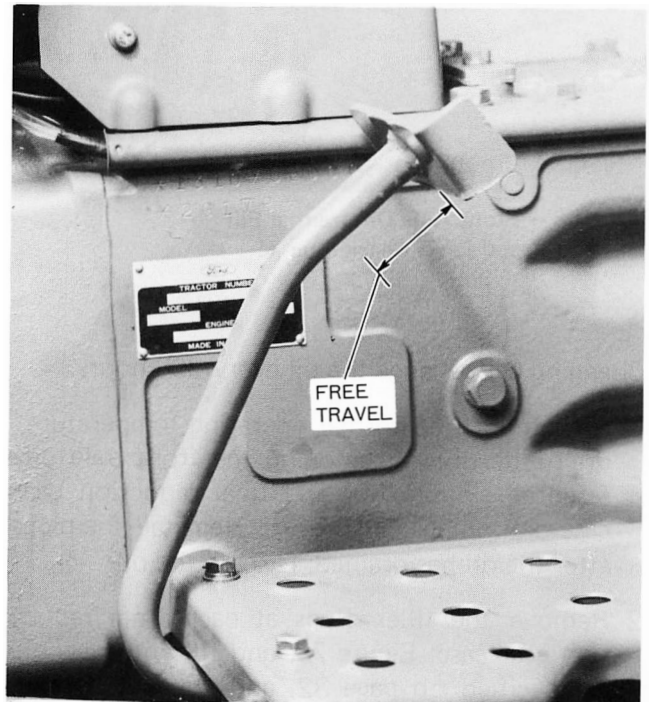

Figure 67 – Clutch Pedal Free Travel Adjustment

## FOUR-WHEEL DRIVE

### FRONT AXLE DIFFERENTIAL CASE AND FINAL REDUCTION GEAR CASES

**Checking Oil Level:** Check the oil level every 50 hours.

1. With the tractor standing level and the engine off, check the oil level with the dipstick, Figure 68.
2. The oil is at the correct level when the oil level is between the mark and lower end of the dipstick. If low, add new oil of the type specified, page 32, through the combined dipstick/fill plug. Do not fill beyond the mark on the stick, as the transmission will be overfilled.
3. Install the filler plug and dipstick.

# LUBRICATION AND MAINTENANCE

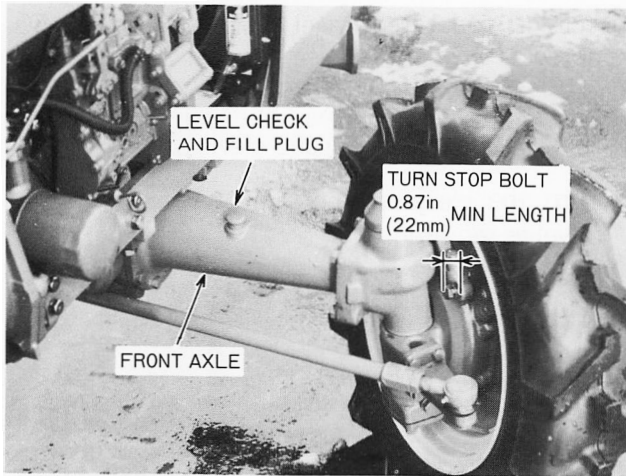

**Figure 68 – Front Axle Differential Fill and Level Check Plug**

Changing Oil: Change the oil every 300 hours.

1. With the oil at normal operating temperature, drain the oil by removing the front axle differential, Figure 69, and final reduction gear case drain plugs, Figure 70. Reinstall the plugs after the oil has drained. Discard the oil.
2. Remove the filler plugs at each final reduction gear case, Figure 70, and fill with new oil as specified on page 32, and install the filler plug.

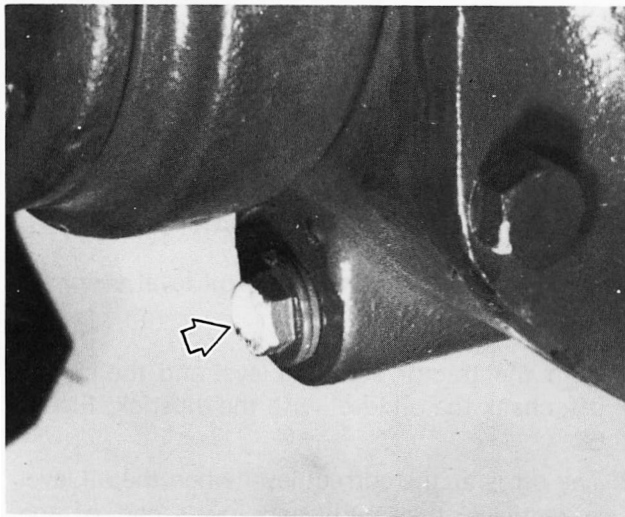

**Figure 69 – Front Axle Differential Drain Plug**

3. Remove the filler plug on the top, right side of axle housing, Figure 68, and fill with new oil of the type specified, page 32.

4. The front axle is filled to correct level when the oil level is between the mark and lower end of the stick. Do not fill beyond the mark on the stick, as the front axle will be overfilled.
5. Install the dipstick/filler plug.

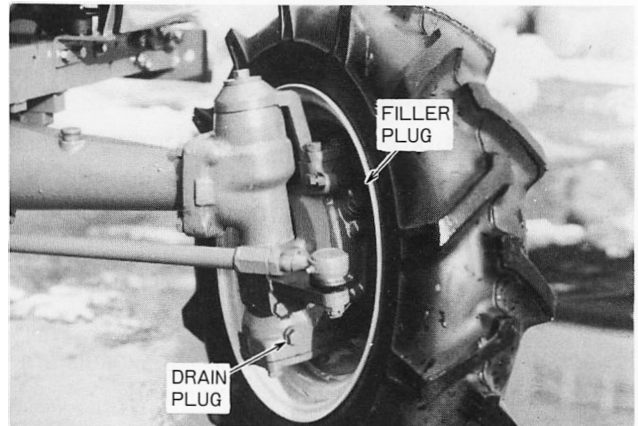

**Figure 70 – Final Reduction Gear Case Fill and Drain Plugs**

## FRONT AXLE PIVOT

Grease the center housing pivot point, Figure 71, after every 50 hours of operation under normal conditions. In extremely dirty conditions, lubrication should be made more often. Use a good quality, multi-purpose, lithium base grease.

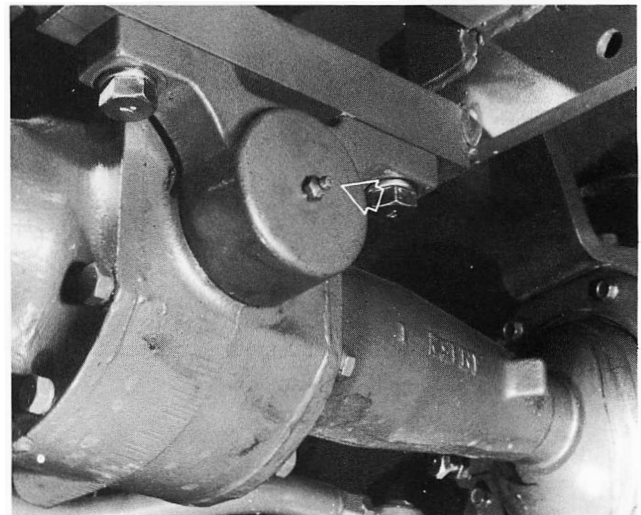

**Figure 71 – Front-Axle Pivot Point**

# LUBRICATION AND MAINTENANCE

## TRACTOR STORAGE

Tractors that are to be stored for an extended period should be protected during storage. The following is a suggested list of operations to be carried out.

1. Thoroughly clean the tractor. Use touch-up paint where necessary to prevent rust.
2. Check the tractor for worn or damaged parts. Install new parts as required.
3. Raise the lift arms hydraulically to their fully raised position so the lift piston is in a fully extended position. This fills the cylinder with oil and will protect the cylinder wall surfaces from corrosion.
4. Lubricate the tractor. Drain and refill the transmission, hydraulic system and rear axle with new oil. Drain the engine oil and refill with new lubricating oil. Also clean the air cleaner.
5. If the tractor is stored or removed from operation for an extended period, special precautions should be taken to protect the fuel injection pump and the injector nozzles against corrosion and gumming during the storage period.

- Before storing, the fuel system should be flushed with a special oil, a quantity of which will remain in the system when the engine is shut down for storage.
- Special diesel fuel system flushing oils are available from most oil companies. If special flushing oil is not readily obtainable, mix one U.S. pint (0.8327 Imp. pt.) (.473 liters) of SAE 10 non-detergent engine oil with 10 U.S. quarts (8.33 Imp. qts.) (9.46 liters) of No. 2 diesel fuel.
- Drain the fuel tank and pour two U.S. gallons (1.67 Imp. gals.) (7.57 liters) of the special flushing oil (or lubricating mixture) in the fuel tank.
- Run the engine for 10 minutes to ensure complete distribution of the special oil through the injection pump and fuel injectors. There is no need to remove the injector nozzles.

- Fill the fuel tank with No. 1 diesel fuel.

**IMPORTANT:** Do not use No. 2 diesel fuel for winter storage because of wax separation and setting at low temperatures.

6. Drain the radiator and engine block. Flush the system, close the drain valves, and fill with a 50/50 solution of permanent antifreeze and clear water.
7. Remove the battery and clean it thoroughly. Be sure that it is fully charged, and that the electrolyte is at the proper level. Place it in storage in a cool, dry place above freezing temperature. The battery should be charged periodically during storage.
8. Place blocking under the tractor axles to remove the weight from the tires.
9. Cover the exhaust pipe opening.
10. Place pedal spacer between clutch pedal and step plate to separate clutch disc from flywheel (Figure 72).

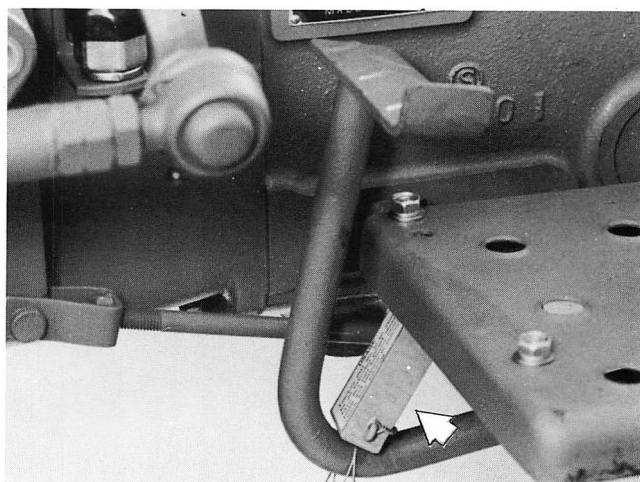

Figure 72 — Installing Pedal Spacer

## LUBRICATION AND MAINTENANCE ---

Tractors that have been placed in storage should be completely serviced in the following manner before using:







1. Inflate the tires to the recommended pressures, and remove the blocking.
2. Check the oil level in the engine crankcase, the common sump (for the hydraulic lift, transmission, rear axle and optional power steering), and optional front wheel drive axle.
3. Install a fully-charged battery and remove the exhaust cover, if other than a rain cap.
4. Check the cooling system for proper level of 50/50 solution of antifreeze and clear water.
5. Remove pedal spacer from between clutch pedal and step plate.
6. Start the engine and allow it to idle a few minutes. Be sure the engine is receiving lubrication and that each control is functioning correctly.
7. Drive the tractor without a load and check to be sure it is operating satisfactorily.

# LUBRICATION AND MAINTENANCE

## GENERAL TORQUE SPECIFICATION TABLE (Revised 2-74)













### USE THE FOLLOWING TORQUES WHEN SPECIAL TORQUES ARE NOT GIVEN

**NOTE:** These values apply to fasteners as received from supplier, dry, or when lubricated with normal engine oil. They do not apply if special graphited or moly disulphide greases or other extreme pressure lubricants are used. This applies to both UNF and UNC threads.

SEE Grade No.		2				5				8 *			
Bolt head identification marks as per grade NOTE: Manufacturing Marks Will Vary						  				  			
		Bolt Size		Torque		Torque		Torque		Torque		Torque	
Inches	Millimeters	Pounds Feet	Newton-Meters	Pounds Feet	Newton-Meters	Pounds Feet	Newton-Meters	Pounds Feet	Newton Meters	Pounds Feet	Newton Meters		
		Min.	Max.	Min.	Max.	Min.	Max.	Min.	Max.	Min.	Max.		
1/4	6.35	5	6	6.8	8.13	9	11	12.2	14.9	12	15	16.3	30.3
5/16	7.94	10	12	13.6	16.3	17	20.5	23.1	27.8	24	29	32.5	39.3
3/8	9.53	20	23	27.1	31.2	35	42	47.5	57.0	45	54	61.0	73.2
7/16	11.11	30	35	40.7	47.4	54	64	73.2	86.8	70	84	94.9	113.9
1/2	12.70	45	52	61.0	70.5	80	96	108.5	130.2	110	132	149.2	179.0
9/16	14.29	65	75	88.1	101.6	110	132	149.2	179.0	160	192	217.0	260.4
5/8	15.88	95	105	128.7	142.3	150	180	203.4	244.1	220	264	298.3	358.0
3/4	19.05	150	185	203.3	250.7	270	324	366.1	439.3	380	456	515.3	618.3
7/8	22.23	160	200	216.8	271.0	400	480	542.4	650.9	600	720	813.6	976.3
1	25.40	250	300	338.8	406.5	580	696	786.5	943.8	900	1080	1220.4	1464.5
1-1/8	25.58	—	—	—	—	800	880	1084.8	1193.3	1280	1440	1735.7	1952.6
1-1/4	31.75	—	—	—	—	1120	1240	1518.7	1681.4	1820	2000	2467.9	2712.0
1-3/8	34.93	—	—	—	—	1460	1680	1979.8	2278.1	2380	2720	3227.3	3688.3
1-1/2	38.10	—	—	—	—	1940	2200	2630.6	2983.2	3160	3560	4285.0	4827.4

\* Thick nuts must be used with Grade 8 bolts.

## METRIC BOLT TORQUE SPECIFICATIONS

Bolt Size	Grade No.	Coarse Thread			Fine Thread		
		Pitch (mm)	Pounds-Feet	Newton-Meters	Pitch (mm)	Pounds-Feet	Newton-Meters
M6	4T    	1.0	3.6— 5.1	4.9— 6.9	—	—	—
	7T    		6.1— 8.3	8.3— 11.3			
	10T    		8.7— 11.6	11.8— 15.7			
M8	4T	1.25	9.4— 12.3	12.7— 16.7	1.0	11.2— 14.8	15.2— 20.1
	7T		16.6— 21.0	22.6— 28.4		19.5— 25.3	26.5— 34.3
	10T		21.0— 26.8	28.4— 36.3		22.4— 29.7	30.4— 40.2
M10	4T	1.5	18.8— 24.6	25.5— 33.3	1.25	21.0— 26.8	28.4— 36.3
	7T		32.5— 41.2	44.1— 55.9		36.2— 46.3	49.0— 62.8
	10T		39.8— 51.4	53.9— 69.6		42.7— 54.2	57.9— 73.5
M12	4T	1.75	27.5— 34.7	37.3— 47.1	1.25	31.8— 40.5	43.1— 54.9
	7T		48.5— 61.5	65.7— 83.4		55.0— 69.4	74.5— 94.1
	10T		68.0— 85.4	92.2— 116		73.1— 93.3	99.0— 127
M14	4T	2.0	46.3— 59.3	62.8— 80.4	1.5	51.4— 64.4	69.6— 87.3
	7T		76.7— 96.9	104 —131		86.1—109	117 —148
	11T		102 —129	139 —175		108 —137	147 —186
M16	4T	2.0	63.6— 81.0	86.3— 110	1.5	67.3— 84.6	91.2— 115
	7T		110 —136	149 —184		116 —142	157 —192
	11T		152 —188	206 —255		163 —199	221 —270
M18	4T	2.0	83.9— 104	114 —141	1.5	96.9— 120	131 —163
	7T		145 —174	196 —235		170 —206	230 —279
	11T		203 —246	275 —333		221 —271	299 —368
M20	4T	2.5	106 —132	144 —179	1.5	127 —156	172 —211
	7T		177 —213	240 —289		203 —246	275 —333
	11T		268 —325	363 —441		293 —358	397 —485

## SPECIFICATIONS

The specifications on the following pages are provided for your information. For additional information, see your Ford Tractor-Equipment Dealer.



**Properly Maintained Equipment  
is Safe Equipment**

"Ford Motor Company, whose policy is one of continuous improvement, reserves the right to make changes in design and specifications at any time without notice and without obligation to modify units previously built."

# SPECIFICATIONS

## ENGINE

<b>Type</b>	<b>Diesel</b>
Number of Cylinders	3
Bore	3.31 in. (8.4 cm)
Stroke	3.31 in. (8.4 cm)
Displacement	85.18 cu. in. (1396 cc)
Compression Ratio	23 : 1
Firing Order	1-2-3
Low Idle Speed	750-850 rpm
Maximum Speed:	
High Idle	2825-2875 rpm
Rated	2700 rpm
Valve Clearance (Cold Engine):	
Intake	.008 in. (.2 mm)
Exhaust	.008 in. (.2 mm)

## CAPACITIES

Fuel Tank	7.5 U.S. Gals. 6.3 Imp. Gals. 28.6 Liters
Cooling System	4.2 U.S. Qts. 3.5 Imp. Qts. 4 Liters
Engine Crankcase:	
Less Filter	4.8 U.S. Qts. 4 Imp. Qts. 4.5 Liters
With Filter Change	5.3 U.S. Qts. 4.4 Imp. Qts. 5 Liters
Rear Axle and Transmission	27.5 U.S. Qts. (Includes Hydraulics and Optional Power Steering) 23 Imp. Qts. 26 Liters
Front Axle Differential Case and Final Reduction	4.2 U.S. Qts. 3.5 Imp. Qts. 4 Liters

## COOLING SYSTEM

Type	Pressurized Liquid with Recirculating Bypass
Water Pump:	
Type	Centrifugal
Drive	V-Belt
Water Pump Belt	
Deflection	7/16 to 9/16 (10-15 mm) when 20-25 lbs. (9-11 kg) Thumb Force is Applied Midway Between Pulleys.

## COOLING SYSTEM — Cont'd.

Fan Diameter	13.8 in. (35 cm)
Thermostat:	
Start to Open	160°F (71°C)
Fully Open	185°F (85°C)
Radiator Cap	12.8 psi (.88 bar)

## ELECTRICAL SYSTEM

Alternator	12-volt, Heavy Duty, 35 amps
Regulator (Alternator)	Mechanical
Battery	12-volt, 70 amp. Hour Rating with Negative Ground
Starting Motor	Solenoid, Pre-Engaged

## FUEL SYSTEM

Type of Fuel to Use	Temperature	Type
Diesel	Above 20°F (-6.7°C)	No. 2D Cetane Rating min. 40
	Below 20°F (-6.7°C)	No. 1D Cetane Rating min. 40
Injection Pump:		
Type		In-Line
Timing		23° BTDC

## CLUTCH

Type	8.5 in. (21.59 cm) Dry Disc., Organic Face
Pedal Free-Travel	3/4-1-3/16 in. (19-30 mm)

## BRAKES

Type	Drum (Expanding Shoe)
Drum	5.9 in. Diameter (15.0 cm)

## STEERING

Type	Manual or Hydraulic power assist
Turn Lock-to-Lock	2.3
Steering Wheel Free-Play	0.78-1.38 in. (20-35 mm)
Front Wheel Toe-In	0-13/64 in. (0-5 mm)
Turning Radius (Without Brake)	8.4 ft. (255 cm) Two Wheel Drive 9.1 ft. (276 cm) Four Wheel Drive

# SPECIFICATIONS

## POWER TAKE-OFF

Type . . . . . Transmission  
 Shaft . . . . . 1-3/8 in. (3.49 cm)  
 6 Spline SAE STD  
 Engine Speed for 540 rpm  
 PTO Operation . . . . . 2422  
 Horsepower PTO  
 Observed . . . . . 23.5

## HYDRAULIC LIFT SYSTEM

Type . . . . . Live Category 1  
 3-point Linkage  
 Pump Type . . . . . Gear  
 Pump Capacity . . . . . 7.8 U.S. gpm @  
 (W/Power Steering) 2133 psi at 2700 rpm  
 (6.5 Imp. gpm @  
 147 bar @ 2700 rpm)  
 . . . . . 6.5 U.S. gpm @  
 (W/O Power Steering) 2133 psi at 2700 rpm  
 (5.4 Imp. gpm @  
 147 bar @ 2700 rpm)  
 System Relief Valve  
 Setting . . . . . 2133 psi (147 bar)

## LUBRICANTS

TRACTOR COMPONENT	LUBRICANT RECOMENDATION	FORD PART NO.
Engine Oil . . . . .	FORD Super Premium . . . . .	1QM-2C 121-AMV (Case-24 Qts. 15W-40) 1QM-2C 121-A10 (Case-24 Qts. SAE 10W) 1QM-2C 121-A30 (Case-24 Qts. SAE 30W)
Transmission, Rear Axle, Power Steering and Hydraulic System Oil . . . . .	FORD 134 . . . . .	1GM-134C (1 Gal.) 5GM-134C (5 Gal.)
Front Wheel Bearings and Lubrication Fittings . . . . .	M1C-137-B . . . . .	1TM-1C-137-B (1 Tube)
Front Axles . . . . .	FORD 134 . . . . .	1 GM-134C (1 Gal.) EOAZ-19580-E (5 Gal.)

**NOTE:** Should the recommended engine oil not be readily available, use a commercial oil as shown in the following chart.

## TIRES

Front:

Standard (AG) . . . . .

Two Wheel Drive	Four Wheel Drive
5.00-15, F2, 4PR	6.00-16, R1, 4PR

Optional (TURF)

Two Wheel Drive	Four Wheel Drive
23-8.50-12, 4PR	27-8.50-15, 4PR

Rear:

Standard (AG) . . . (Two & Four Wheel Drive)  
 11.2 x 24, R1, 4PR

Optional (TURF) . (Two & Four Wheel Drive)  
 13.6-16, R3, 4PR

## WHEEL BOLT TORQUES

Front Wheel

Disc-to-Hub . . . . .

Two Wheel Drive	Four Wheel Drive
43-54 lb. ft. (58-73 N.m)	137-159 lbs. ft. (186-215 N.m)

Rear Wheel

Disc-to-Rim . . . . . 137-159 lbs. ft.  
 (186-215 N.m)

Rear Wheel

Disc-to-Axle . . . . . 137-159 lbs. ft.  
 (186-215 N.m)

## ROPS ATTACHING BOLT TORQUES

ROPS to Trumpet Hsg (M12) . . . . . 80 lbs. ft.  
 (108 N.m)  
 ROPS to Lower Mount (M20) . . . . . 110 lbs. ft.  
 (152 N.m)  
 ROPS Crossmember Attachment . . . . . 60 lbs. ft.  
 (81 N.m)  
 Seat Belt (M12) . . . . . 80 lbs. ft.  
 (108 N.m)

# SPECIFICATIONS

**IMPORTANT:** Engine crankcase oil drain intervals should be adjusted downward when diesel fuel sulfur content is above 0.5%. (See page 32.)

## CAST IRON WEIGHTS

- (3) Front End Weights. . . . . 33 lbs.  
(15 kg) each
- (4) Front Wheel Weights  
(Two Wheel Drive Only) . . . . . 33 lbs.  
(15 kg) per wheel
- (4) Rear Wheel Weights . . . . . 66 lbs.  
(30 kg) each

## Draw Bars

- Fixed. . . . . Standard
- Adjustable. . . . . Optional

## GENERAL DIMENSIONS

	Two Wheel Drive	Four Wheel Drive
Length	117.5 in. (298.5 cm)	117.5 in. (298.5 cm)
Wheelbase	63 in. (160 cm)	63 in. (160 cm)

	Two Wheel Drive	Four Wheel Drive
Height:		
Top of Steering Wheel	57.3 in. (145.5 cm)	57.9 in. (147 cm)
Top of ROPS	86.61 in. (220.0cm)	86.61 in. (220.0cm)
Top of Vertical Exhaust	73.3 in. (186.2 cm)	74.5 in. (189.2 cm)
Width:	59.3 in. (150.5 cm)	59.3 in. (150.5 cm)
Minimum Ground Clearance	13.9 in. (35.4 cm)	13.9 in. (35.4 cm)
Adjustable Width:		
Front	43.5 – 57.5 in. (110.5 – 146 cm)	45.2 in. (115 cm)
Rear	43.3-58.7 in. (110 – 149 cm)	43.3-58.7 in. (110 – 149 cm)
Weight (W/ROPS) (Less Options)	2347 lbs. (1065 kg)	2557 lbs. (1160 kg)

## GROUND SPEEDS

**From 1350 - 2700 RPM Engine Speed  
with 11.2 x 24 Rear Tires**

GEAR POSITION	MILES PER HOUR													
	1	2	3	4	5	6	7	8	9	10	11	12	13	
1st	0.4 0.8													
2nd	0.5 1.0													
3rd	0.6 1.2													
4th	0.9	1.7												
5th		1.1	2.2											
6th		1.4	2.8											
7th			1.9	3.8										
8th			2.4		4.8									
9th				3.1		6.2								
10th					3.8		7.6							
11th						4.9			9.7					
12th							6.3				12.6			
R1	0.4 0.9													
R2		1.0	2.0											
R3			2.2		4.3									
R4					4.4				8.8					
	0	1.6	3.2	4.8	6.4	8.0	9.6	11.2	12.8	14.4	16.0	17.6	19.2	20.8
	KILOMETERS PER HOUR													

# SAFETY DECALS

In the event that decals become damaged or illegible, they should be replaced with new decals at their original position.



## WARNING

- Pull only from drawbar. Pulling from any other point can cause rear overturn.
- Do not operate with unshielded PTO. ● Disengage PTO and stop engine before servicing tractor or implements or attaching and detaching implements.
- Position drawbar at 14" from end of PTO shaft to drawbar hole for 540 and 16" for 1000 PTO RPM. ● When towing equipment use a safety chain.

**FAILURE TO FOLLOW ANY OF THE INSTRUCTIONS ABOVE CAN CAUSE SERIOUS INJURY TO THE OPERATOR OR OTHER PERSONS.**

WARNING – Pull only from drawbar  
 PART NO. – SBA-390192291  
 LOCATION – Top of PTO shaft.



## WARNING

- Before starting and operating
  - Know the operating and safety instructions in the operators manual and on the tractor.
  - Clear the area of bystanders.
  - Locate and know operation of controls.
  - Fasten your seat belt.
- Start engine only from operators seat with transmission in neutral, PTO disengaged and hydraulic controls in lowered position.
- Slow down on turns, rough ground and slopes to avoid upset.
- Do not permit anyone but the operator to ride on the tractor. There is no safe place for riders.
- Lock brakes together, use warning lights and SMV emblem while driving on roads.
- Lower equipment, place gear shift levers in neutral, stop engine and apply parking brake before leaving tractor seat.
- Avoid accidental contact with gear shift lever while engine is running. Unexpected tractor movement can result.

**FAILURE TO FOLLOW ANY OF THE INSTRUCTIONS ABOVE CAN CAUSE SERIOUS INJURY TO THE OPERATOR OR OTHER PERSONS.**

[Replacement manuals are available from your FORD tractor dealer or from FORD Tractor Service Publications – P. O. Box 07150 – Detroit, Michigan 48207



## WARNING

- Start engine only from operators seat, if safety start switch is bypassed engine can start with transmission in gear.
- Do not connect or short across terminals on starter solenoid.
- Attach booster cables as shown on battery decal.

**Starting in gear causing runaway can result in serious injury.**

WARNING – Start engine only from operators seat.  
 PART NO. SBA-190196681.  
 LOCATION – On the starting motor.



## WARNING

KEEP HANDS AND CLOTHING AWAY FROM ROTATING FAN AND BELTS TO PREVENT SERIOUS INJURY

WARNING – Keep hands and clothing away from rotating fan.  
 PART NO. – SBA-390191351.  
 LOCATION – Rear of radiator.



**POISON/DANGER**  
**CAN PRODUCE EXPLOSIVE GASES AND CAUSE SEVERE BURNS**

Sulfuric acid electrolyte. Avoid contact with skin, eyes or clothing. Antidote: EXTERNAL-Flush with water. INTERNAL-Drink large quantities of water or milk. Follow with milk of magnesia, beaten eggs or vegetable oil. Call physician immediately. EYES: Flush with water for 15 minutes and get prompt medical attention. Batteries produce explosive gases. Keep sparks, flame, cigarettes away. Do not produce sparks with cable clamps or tools. Ventilate when charging or using in enclosed space. Always shield eyes when working near batteries. Keep vent caps tight and level.

KEEP OUT OF REACH OF CHILDREN



FORD TRACTOR OPERATIONS. TROY, MICH. 48084

TO JUMP START: (Negative Grounded Battery)

1. Shield eyes. 2. Connect ends of one cable to positive (+) terminals of each battery. 3. Connect one end of other cable to negative (-) terminal of "Good" battery. 4. Connect other end to engine block of vehicle being started. 5. Reverse procedure when disconnecting.

Replace with:     **F180**

POISON/DANGER – TO JUMP START  
 PART NO. – SBA-390193250  
 LOCATION – On the battery.

WARNING – Before starting and operating.  
 PART NO. – SBA-390192272  
 LOCATION – Center of R. H. fender.

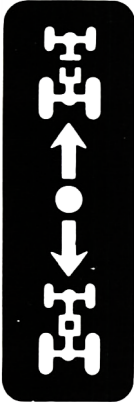

**Four-Wheel Drive Control Lever**  
 PART NO. – SBA-390170630.  
 LOCATION – On the change lever case right side.



**Creeper Range Lever (Optional)**  
 PART NO. – SBA-390170680.  
 LOCATION – On the creeper change lever case left side.

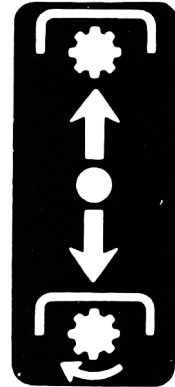

**PTO Control Lever**  
 PART NO. – SBA-390170650.  
 LOCATION – On the L. H. rear axle housing.



**Shuttle Shift Lever – Option**  
 (12 x 4 Synchronesh Transmission)  
 PART NO. – SBA-390171220  
 LOCATION – On the shuttle shift cover.



**Flow Control Valve**  
 PART NO. – SBA-390370290.  
 LOCATION – Top of flow control knob.

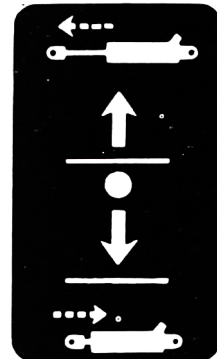

**Remote Control Lever (Optional)**  
 PART NO. – SBA-390370300.  
 LOCATION – Front of quadrant bracket.

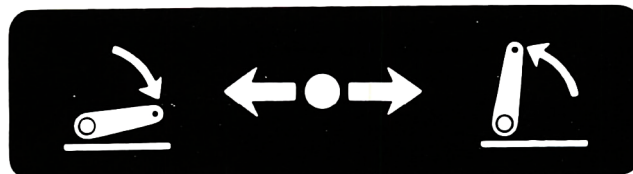

**Hydraulic Lift Control Lever**  
 PART NO. – SBA-390370280.  
 LOCATION – Center of R.H. fender.

# INSTRUCTION DECALS

---



**Starter Switch**  
 PART NO. – SBA-390190030.  
 LOCATION – Starter Switch, right side of instrument panel.



**Cold Start Aid**  
 PART NO. – SBA-390191370.  
 LOCATION – Glow plug indicator left side of instrument panel.



**Flasher Warning Light Switch**  
 PART NO. – SBA-390191390.  
 LOCATION – Safety flasher switch, right of instrument panel.



**Hand Throttle Control Lever**  
 PART NO. – SBA-390430100.  
 LOCATION – Hand throttle lever, right side of instrument panel.



**Diesel Fuel**  
 PART NO. – SBA-390192840  
 LOCATION – Under the fuel fill lid.



**HYD. Manifold Operation**  
 See Operator Manual  
 PART NO. – SBA-390192850  
 LOCATION – R. H. side of Hyd. Manifold.

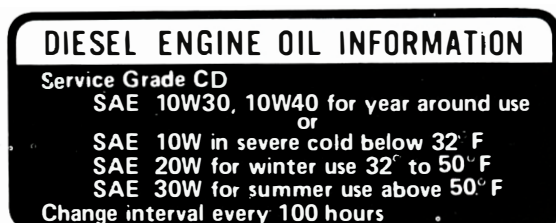

**Diesel Engine Oil Information**  
 PART NO. – SBA-190196490.  
 LOCATION – Left side of engine cylinder head cover.

**WATCH YOUR  
PROOF METER HOURS  
LUBRICATION AND MAINTENANCE  
SERVICE INTERVALS**

LUBRICATION AND MAINTENANCE ITEM	CHECK	CLEAN	LUBE	CHANGE	ADJUST	SERVICE INTERVAL
Radiator Engine Oil Level Air Cleaner	●					Every 10 Hours or Daily
Transmission Oil Level Front Diff Oil Level Front Axle Oil Level Tires Clutch Pedal Battery Lubrication Fittings Steering linkage Front wheel spindles 3-point linkage	●				●	Every 50 Hours
Engine Oil Fuel Filter Air Cleaner		●		●		Every 100 Hours
Fuel Filter Engine Oil Filter Fan Belt Brakes Steering Free-Play				●	●	Every 200 Hours
Front Axle Oil Front Diff Oil Transmission—Rear Axle Oil				●	●	Every 300 Hours
Fuel Injectors Hydraulic Filter	●			●	●	Every 600 Hours
Radiator Coolant Air Cleaner Element				●	●	Seasonal

Refer to your Operator's Manual  
for additional information

Lubrication and Maintenance Service Intervals  
PART NO. — SBA-390191310.  
LOCATION — On the fuel tank.

**IMPORTANT**

- For normal operation on firm soil, hard surfaces and roading the unit, front wheel drive should be disengaged to maximize tire and driveline life and fuel economy
- Only use front wheel drive when additional traction is required while operating in loose soil, wet, slippery conditions or on slopes.

IMPORTANT — For normal operation  
PART NO. SBA-390192410  
LOCATION — Center of R.H.fender.

# NOTES

**PRE-DELIVERY SERVICE  
CHECK AND ADJUST AS REQUIRED**

**INOPERATIVE SERVICE CHECKS**

1. Tire pressure . . . . .
2. Air cleaner oil level and hose connections . . . . .
3. Radiator coolant level . . . . .
4. Fan belt tension . . . . .
5. Battery cleanliness, vent openings, electrolyte level, and charge . . . . .
6. Engine oil level . . . . .
7. Transmission and rear axle oil level . . . . .
8. Front Axle and Front Diff oil level (4WD) . . . . .
9. Hydraulic Lift control adjustment . . . . .
10. Upper link, and hitch . . . . .
11. Brake adjustment and pedal equalization . . . . .
12. Rear wheel disc and hub bolts for tightness . . . . .
13. Front wheel disc and hub nuts for tightness (2WD) . . . . .
14. Front wheel disc and hub bolts for tightness (4WD) . . . . .

15. Front wheel toe-in . . . . .
16. Fuel level . . . . .
17. Sheet metal and paint condition . . . . .
18. Check lift rod for proper operation . . . . .
19. Drain diesel fuel filter . . . . .

**SAFETY ITEMS CHECKS**

1. ROPS installed . . . . .
2. Seat belts installed . . . . .
3. PTO master shield installed . . . . .
4. SMV emblem installed . . . . .
5. Safety decals installed . . . . .
6. Neutral start switch operation . . . . .
7. Park brake & latch operation . . . . .
8. Flashing lights/tail lights operation . . . . .
9. Operator's Manual . . . . .

**OPERATIVE SERVICE CHECKS**

All operating checks are to be performed with the tractor at normal operating temperature

1. Lights and instruments for proper operation . . . . .
2. Fluid and oil leaks . . . . .
3. Maximum no-load speed and idle speed adjustments, and fuel shutoff . . . . .
4. P.T.O. engagement and disengagement
  - Clutch pedal and P.T.O. lever . . .
5. Hydraulic System:
  - Selection lever for position control operation . . . . .
  - Flow control operation . . . . .
6. 4-wheel drive lever operation . . . . .
7. Low speed (creeper) lever . . . . .
8. Operation of H.S.T. . . . .

TRACTOR MODEL NO. \_\_\_\_\_

INSEPTION PERFORMED  
WARRANTY EXPLAINED

TRACTOR SERIAL NO. \_\_\_\_\_

OWNER'S SIGNATURE

DATE

DEALER'S SIGNATURE

DATE

**50-HOUR SERVICE  
CHECK AND ADJUST AS REQUIRED**

**INOPERATIVE SERVICE CHECKS**

1. Tire pressure . . . . .
2. Check air cleaner hose connection . . . . .
3. Replace diesel fuel filter(s) . . . . .
4. Tighten in-line pump delivery valve holders . . . . .
5. Radiator coolant level . . . . .
6. Fan belt tension . . . . .
7. Battery cleanliness and vent openings, electrolyte level and charge . . . . .
8. All electrical cables, terminals and wires . . . . .
9. Drain and refill engine oil . . . . .
10. Replace engine oil filter . . . . .
11. Transmission and rear axle oil level . . . . .
12. Front differential and front axle oil level (4WD) . . . . .
13. Injection pump timing . . . . .
14. Cylinder head bolt torque . . . . .
15. Clean Hydraulic System Oil Filter . . . . .
16. Replace H.S.T. cartridge oil filter . . . . .

**OPERATIVE SERVICE CHECKS**

1. Lights and instruments for proper operation . . . . .
2. Fluid and oil leaks . . . . .
3. Maximum no-load speed and idle speed adjustments, and fuel shutoff . . . . .
4. Starting and starter safety switch . . . . .
5. Valve lash . . . . .
6. Hydraulic System
  - Selector lever for position control operation . . . . .
  - Flow control operation . . . . .

**PERFORMANCE SERVICE CHECKS**

1. Engine operation including throttle and governor operation . . . . .
2. Transmission including clutch . . . . .
3. Steering control . . . . .
4. Differential lock engagement and disengagement . . . . .
5. Brake action . . . . .
6. All optional equipment and accessories . . . . .
7. Hydrostatic Transmission . . . . .

TRACTOR MODEL No. \_\_\_\_\_

INSEPTION PERFORMED

TRACTOR SERIAL NO. \_\_\_\_\_

OWNER'S SIGNATURE

DATE

DEALER'S SIGNATURE

DATE

**PRE-DELIVERY SERVICE**  
**CHECK AND ADJUST AS REQUIRED**

**INOPERATIVE SERVICE CHECKS**

1. Tire pressure . . . . .
2. Air cleaner oil level and hose connections . . . . .
3. Radiator coolant level . . . . .
4. Fan belt tension . . . . .
5. Battery cleanliness, vent openings, electrolyte level, and charge . . . . .
6. Engine oil level . . . . .
7. Transmission and rear axle oil level . . . . .
8. Front Axle and Front Diff oil level (4WD) . . . . .
9. Hydraulic Lift control adjustment . . . . .
10. Upper link, and hitch . . . . .
11. Brake adjustment and pedal equalization . . . . .
12. Rear wheel disc and hub bolts for tightness . . . . .
13. Front wheel disc and hub nuts for tightness (2WD) . . . . .
14. Front wheel disc and hub bolts for tightness (4WD) . . . . .

15. Front wheel toe-in . . . . .
16. Fuel level . . . . .
17. Sheet metal and paint condition . . . . .
18. Check lift rod for proper operation . . . . .
19. Drain diesel fuel filter . . . . .

**SAFETY ITEMS CHECKS**

1. ROPS installed . . . . .
2. Seat belts installed . . . . .
3. PTO master shield installed . . . . .
4. SMV emblem installed . . . . .
5. Safety decals installed . . . . .
6. Neutral start switch operation . . . . .
7. Park brake & latch operation . . . . .
8. Flashing lights/tail lights operation . . . . .
9. Operator's Manual . . . . .

**OPERATIVE SERVICE CHECKS**

All operating checks are to be performed with the tractor at normal operating temperature

1. Lights and instruments for proper operation . . . . .
2. Fluid and oil leaks . . . . .
3. Maximum no-load speed and idle speed adjustments, and fuel shutoff . . . . .
4. P.T.O. engagement and disengagement
  - Clutch pedal and P.T.O. lever . . .
5. Hydraulic System:
  - Selection lever for position control operation . . . . .
  - Flow control operation . . . . .
6. 4-wheel drive lever operation . . . . .
7. Low speed (creeper) lever . . . . .
8. Operation of H.S.T. . . . .

TRACTOR MODEL NO. \_\_\_\_\_

INSEPTION PERFORMED  
WARRANTY EXPLAINED

TRACTOR SERIAL NO. \_\_\_\_\_

---

OWNER'S SIGNATURE                      DATE                      DEALER'S SIGNATURE                      DATE

**50-HOUR SERVICE**  
**CHECK AND ADJUST AS REQUIRED**

**INOPERATIVE SERVICE CHECKS**

1. Tire pressure . . . . .
2. Check air cleaner hose connection . . . . .
3. Replace diesel fuel filter(s) . . . . .
4. Tighten in-line pump delivery valve holders . . . . .
5. Radiator coolant level . . . . .
6. Fan belt tension . . . . .
7. Battery cleanliness and vent openings, electrolyte level and charge . . . . .
8. All electrical cables, terminals and wires . . . . .
9. Drain and refill engine oil . . . . .
10. Replace engine oil filter . . . . .
11. Transmission and rear axle oil level . . . . .
12. Front differential and front axle oil level (4WD) . . . . .
13. Injection pump timing . . . . .
14. Cylinder head boil torque . . . . .
15. Clean Hydraulic System Oil Filter . . . . .
16. Replace H.S.T. cartridge oil filter . . . . .

**OPERATIVE SERVICE CHECKS**

1. Lights and instruments for proper operation . . . . .
2. Fluid and oil leaks . . . . .
3. Maximum no-load speed and idle speed adjustments, and fuel shutoff . . . . .
4. Starting and starter safety switch . . . . .
5. Valve lash . . . . .
6. Hydraulic System
  - Selector lever for position control operation . . . . .
  - Flow control operation . . . . .

**PERFORMANCE SERVICE CHECKS**

1. Engine operation including throttle and governor operation . . . . .
2. Transmission including clutch . . . . .
3. Steering control . . . . .
4. Differential lock engagement and disengagement . . . . .
5. Brake action . . . . .
6. All optional equipment and accessories . . . . .
7. Hydrostatic Transmission . . . . .

TRACTOR MODEL No. \_\_\_\_\_

INSEPTION PERFORMED

TRACTOR SERIAL NO. \_\_\_\_\_

---

OWNER'S SIGNATURE                      DATE                      DEALER'S SIGNATURE                      DATE





Ford Tractor Operations

Troy, Michigan 48084

Ford Motor Company

SE4068B 300810650S 078703-215

Printed in Japan